

Rotary actuators

CRAB series

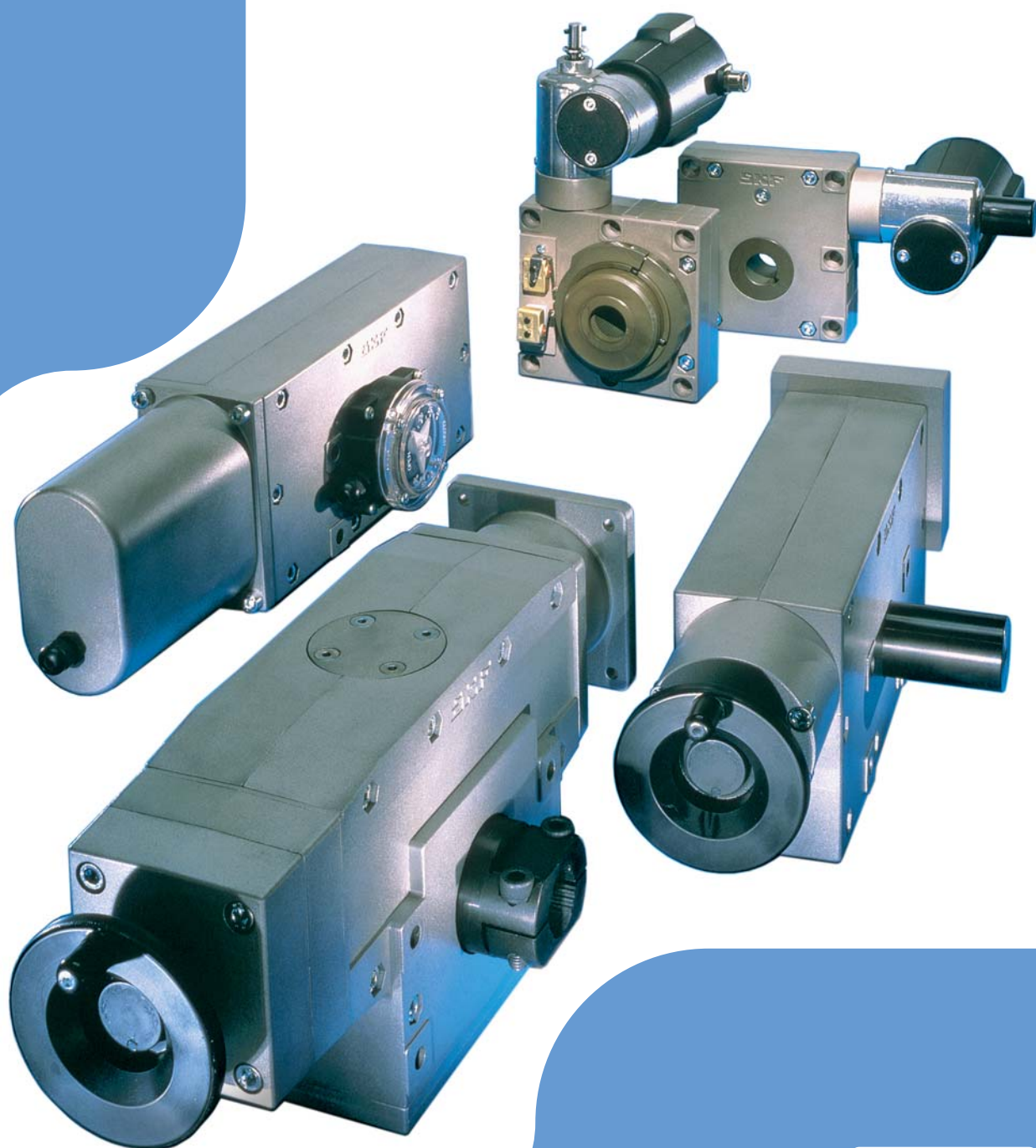



Content

The SKF® brand now stands for more than ever before, and means more to you as a valued customer.

While SKF maintains its leadership as the hallmark of quality bearings throughout the world, new dimensions in technical advances, product support and services have evolved SKF into a truly solutions-oriented supplier, creating greater value for customers.

These solutions encompass ways to bring greater productivity to customers, not only with breakthrough application-specific products, but also through leading-edge design simulation tools and consultancy services, plant asset efficiency maintenance programmes, and the industry's most advanced supply management techniques.

The SKF brand still stands for the very best in rolling bearings, but it now stands for much more.

SKF – the knowledge engineering company

- 3 Rotary actuators, CRAB series
- 4 Define your application
- 4 Choose the precision you need
- 5 Specify the load
- 5 Mount directly
- 6 Tried and tested solutions
- 8 Technical information
- 9 Calculations
- 12 Rotary actuators, CRAB 17
- 13 Performance data, CRAB 17
- 14 Type key, CRAB 17

The direct route to precise positioning

SKF rotary actuators are designed to provide partial rotary motion. Fast or slow. Heavy or light duty. Complex or simple arrangements. You can choose from a wide variety of application areas. And you will find a solution with both technical and economic advantages.

The design of the rotary actuator enables very high torque. Furthermore, the power requirements are modest.

Since the gearing is produced in one stage, through the use of a ball screw, you can also rely on a high degree of efficiency. You can select

the zero-backlash versions for maximum precision.

Our other models provide reliable operation at a lower cost. With SKF rotary actuators you have complete units which are virtually maintenance and lubrication-free. Moreover, they are not sensitive to either high or low temperatures.

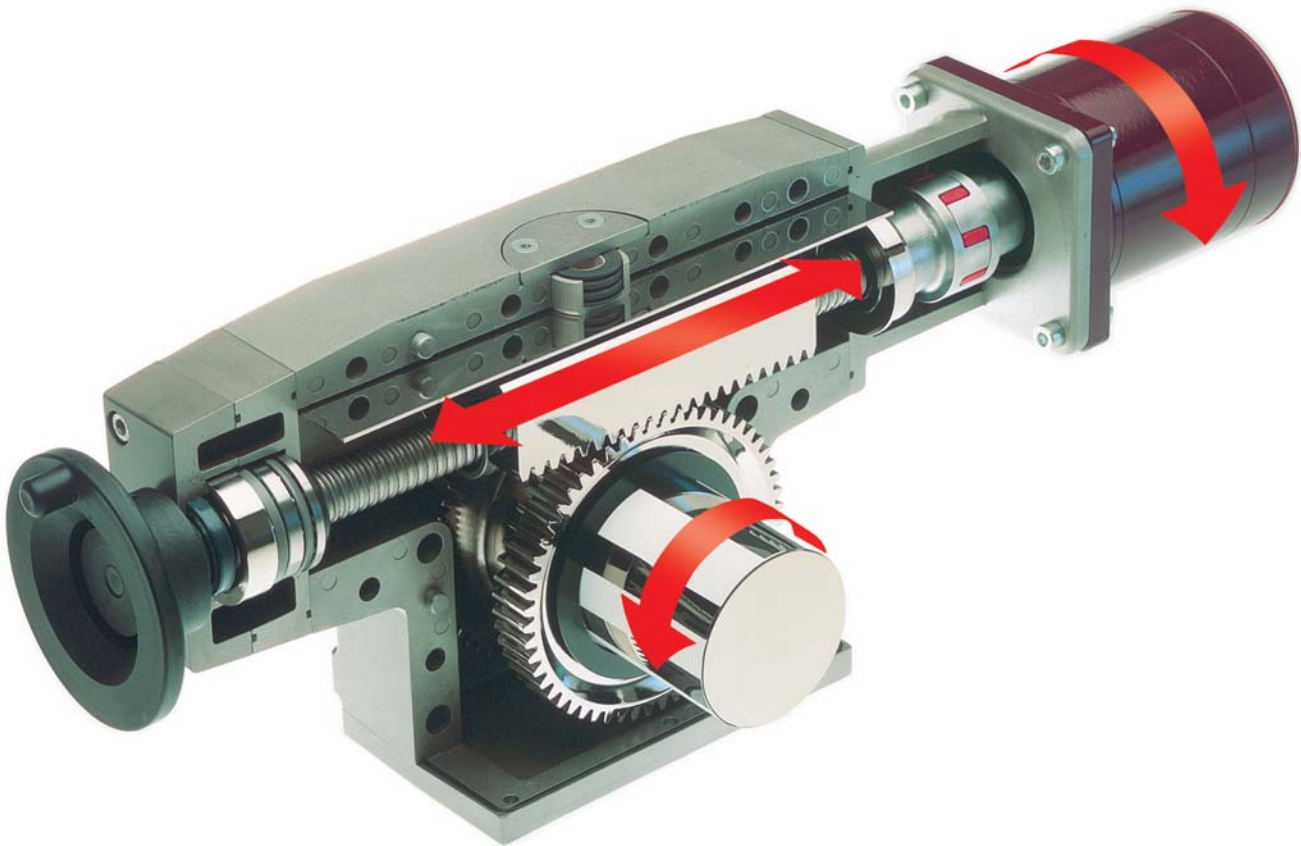

SKF rotary actuators have few moving parts. At the heart of the design lies a ball screw supported in a ball bearing, a gear rack connected to the ball screw nut and a gear wheel/output shaft. When the ball screw rotates, the gear rack makes a linear movement.

This causes the gear wheel and output shaft to rotate. The special geometric design and the straight-cut profile of the gear teeth enable smooth operation with extreme stiffness. The working range of the output shaft depends on the choice of model.

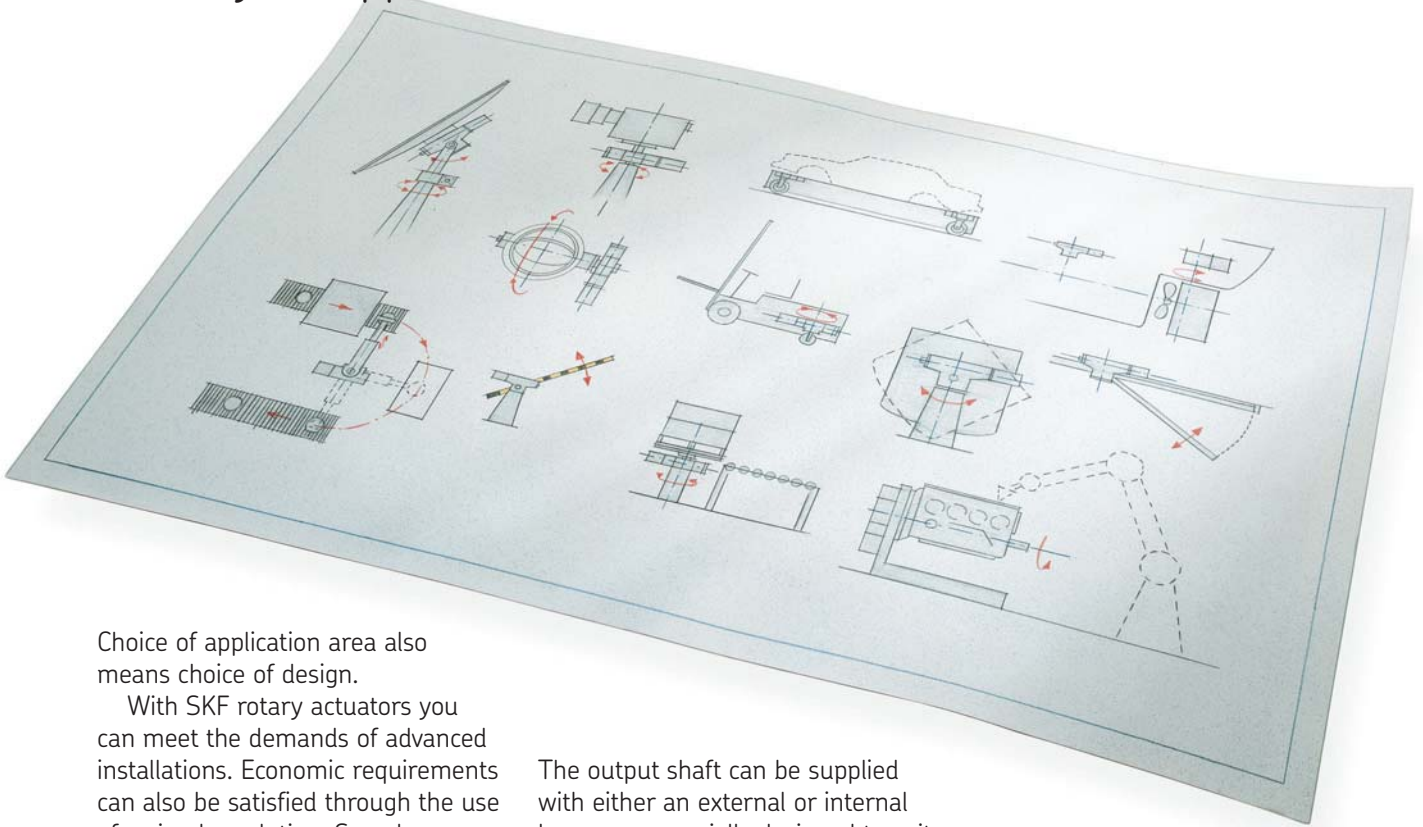

Choice of application area also means choice of design.

With SKF rotary actuators you can meet the demands of advanced installations. Economic requirements can also be satisfied through the use of a simpler solution. Speed can vary from a fraction of a second up to several minutes or more. You can use many different types of drive. This usually takes the form of an electric motor.

The output shaft can be supplied with either an external or internal keyway, or specially designed to suit.

Control techniques may vary, from advanced computer systems to simpler methods. If required, we can supply your rotary actuator with electrical limit switches and me-

chanical position indicator or potentiometer for positioning control. Mechanical emergency operation (hand crank) is standard on all SKF rotary actuators.

Choose the precision you need



Let the precision requirements determine the choice of your rotary actuator. In demanding high-speed-applications with a high duty factor, the natural choice is a rotary actuator which incorporates an SKF ball screw.

These are tried and tested, highly efficient units. Rotary actuators

fitted with ball screws operate without backlash throughout their working life, as they are pre-loaded at all points of contact. Use of the ball screw permits a very high degree of angular resolution, as well as positional stability and precision. In less demanding applications with a low duty factor you could choose a rotary actuator with acme screw. This solution also provides you with a self-locking SKF rotary actuator.

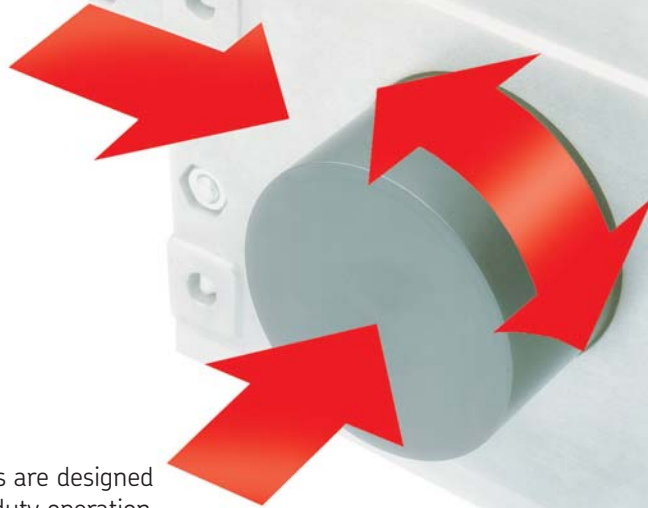

SKF rotary actuators are designed and built for heavy duty operation. Not only in terms of torque but also to support external load.

The output shaft is dimensioned to take considerably heavier loads than those exerted under conditions of maximum torque. This means that it can withstand high bending stresses.

The axial load carrying capacity amounts to several thousand N. As the SKF rotary actuator can withstand extreme loads it can also serve as a load-bearing element of your design. Special bearing arrangements are not usually required. With a custom made shaft,

just attach the rotary actuator to a simple support, couple the equipment to the shaft of the actuator and switch on!

Mount directly



SKF rotary actuators are delivered ready to mount. They are compact units with few component parts in relation to their capabilities. Their simple, robust construction ensures reliable performance for many years of operation.

Four bolts are needed for mounting. The actuators can be used in almost any kind of environment;

hot or cold; dry or damp. There is no need to worry about adjustment or maintenance.

SKF rotary actuators are lubricated for life.



Safety in the distribution of electricity is of great importance all over the world.

Using SKF rotary actuators, major manufacturers in high power switching, are able to design reliable motorized remote-controlled switches. This automatic switching ensures continuity of supply by by-passing a line fault in the event of failure.



A high degree of automation and trouble-free production are two of the motor industry's most important requirements.

For their assembly process, they have installed SKF rotary actuators in order to hold the workpieces exactly in position during the assembly operation. This resulted in increased safety both for the operators and the process.



Accurate weather forecasting is essential for the safety of air traffic. Weather radar systems provide one of the most important means of detecting approaching storms. Each rotation of the antenna requires a rapid and precise adjustment of the angle of inclination. SKF rotary actuators have been chosen for this task.

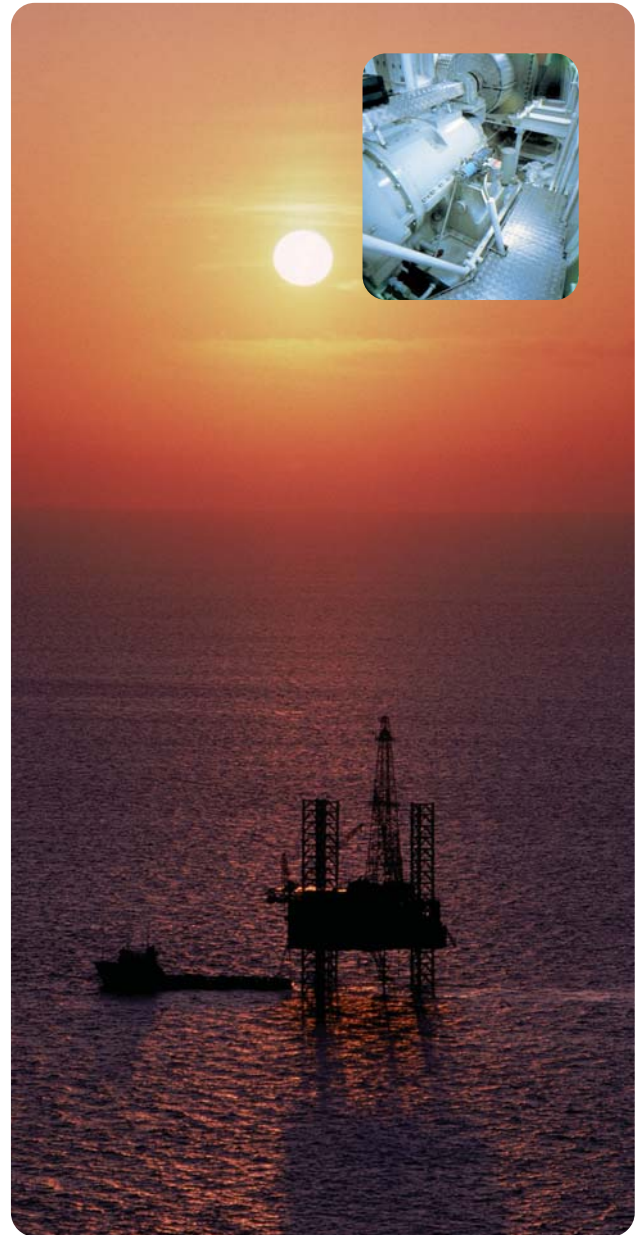

Modern vessels employ variable-pitch propeller blades for manoeuvring. These are often used in conjunction with sophisticated computer systems.

Such is the case with vessels used in diving operations, where the exact position has to be maintained even during bad weather conditions. Using SKF rotary actuators, the propeller blades respond precisely to signals from the computer.

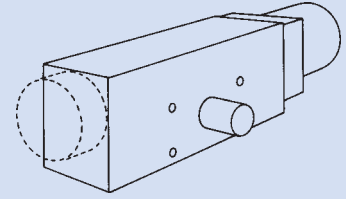
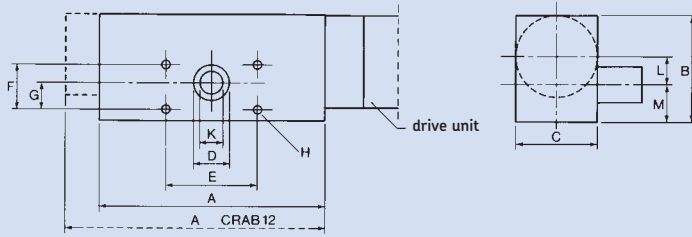

Type	Dimensions in mm														
	A	B	C	D**	E	F	G	H	K*	L	M	Q	R	T	U
CRAB 10	234	120	76	35	100	50	38	8,5	20	36	48	30	6	22,8	6
CRAB 11	234	120	76	35	100	50	38	8,5	20	36	48	30	6	22,8	6
CRAB 12	310	120	76	35	100	50	38	8,5	20	36	48	30	6	22,8	6
CRAB 13	234	120	76	35	100	50	38	8,5	20	36	48	30	6	22,8	6
CRAB 17	120	125	44	42	100	50	38	8,5	28	46	48	37	12	31,3	8

Standard output shaft design

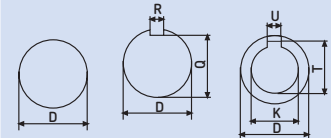

Solid Solid with keyway Hollow shaft with keyway

Other designs are available on request.

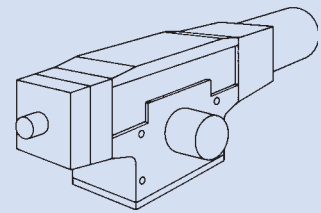
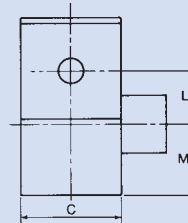
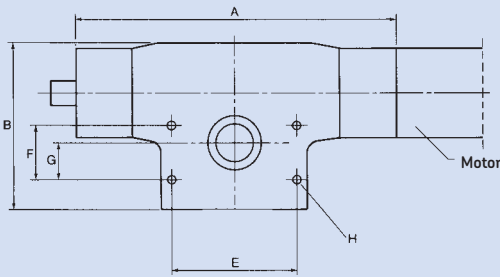

Type	"A" dimensions in mm				Type	Dimensions in mm													
	≤110°	180°	270°	360°		B	C	D**	E	F	G	H	K*	L	M	Q	R	T	U
CRAB 20	306	419	557	720	CRAB 20	155	90	50	120	50	35	8,5	35	46	63	44,5	14	38,3	10
CRAB 30	455	626	846	1 097	CRAB 30	228	122	80	176	85	60	10,5	65	72	92	71	22	69,4	18
CRAB 40	565	768	1 050	1 371	CRAB 40	286	134	100	230	115	80	12,5	80	92	116	90	28	85,4	22

* Max. recommended bore in output shaft, tolerance class H8. Other classes are available.

** Max. recommended tolerance class h8. Other classes are available.

SKF rotary actuators are also available with intermediate angular working ranges. Angular working range is given with a tolerance of ±5°.

Technical data

Actuator	Max. angular working range	Gear ratio		Max. angular speed	Efficiency factor ¹⁾		Max. inst. output torque	Max. ²⁾ axial load	Max. ³⁾ tilting torque	Backlash ⁴⁾		Start ⁵⁾ torque	Temp. ⁶⁾ range	Weight
		Ball screw	Acme screw		Ball screw	Acme screw				Ball screw	Acme screw			
		°		°/s	%	%	Nm	N	Nm	°	°	Nm	°C	kg
CRAB 10	135	-	1:110	180	-	30	75	5 000	160	-	±0,35	≈0,3	-20 to +60	5
CRAB 11	135	-	1:74	120	-	30	200	5 000	160	-	±0,30	≈0,3	-20 to +60	7
CRAB 12	125	1:44	-	120	75	-	200	5 000	160	±0,05	-	≈0,3	-20 to +60	7
CRAB 13	∞	-	1:38	120	-	40	150	5 000	160	-	±0,35	≈0,3	-20 to +60	6
CRAB 17	∞	-	1:52	180	-	50	200	5 000	100	-	±0,25	≈0,3	-20 to +60	3
CRAB 20	360	1:56	1:71	90	75	30	400	10 000	1 120	0,0	±0,20	≈0,5	-20 to +60	9
CRAB 30	360	1:88	1:88	65	75	30	1 000	15 000	3 465	0,0	±0,15	≈1,0	-20 to +60	25
CRAB 40	360	1:113	1:94	45	75	30	1 700	20 000	6 240	0,0	±0,10	≈2,0	-20 to +60	42

¹⁾ Axial load will decrease torque efficiency factor

²⁾ Axial load reduces the output torque

³⁾ Valid when shaft speed is <18°/s

⁴⁾ Measured on the output shaft

⁵⁾ Value by experience. If lower value is needed, contact SKF

⁶⁾ If different temperature range is needed, contact SKF

Contact SKF if higher speed, load or torque is required. SKF rotary actuators designed with acme screw are self-locking

Calculation of service life

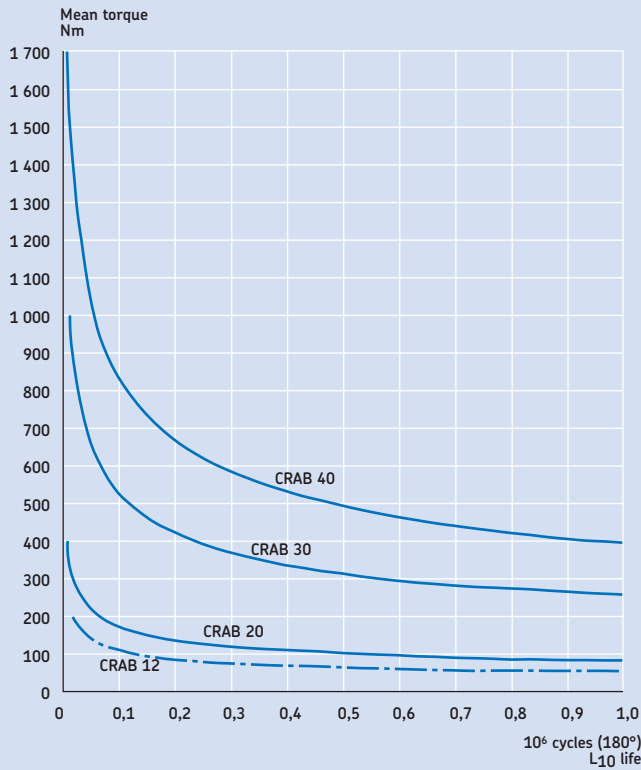

N.B. These diagrams only apply to SKF rotary actuators with BALL SCREW. Always contact SKF whenever you consider ACME SCREW versions.

L_{10} LIFE Calculated L_{10} life related to mean load.

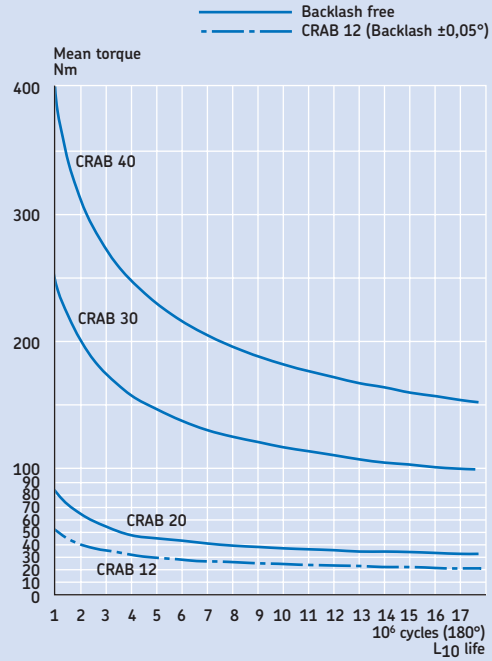

Ball screw actuators

The service life of an SKF rotary actuator is normally determined by the life of the ball screw.

L_{10} is defined as the life that 90 % of a sufficiently large group of apparently identical actuators can be expected to attain or exceed.

Sometimes the life of the motor can be shorter than the life of the ball screw, however, the motor can be easily replaced.

In order to calculate the service life (L_{10}) of an SKF rotary actuator it is necessary to determine the size of the actual mean torque (T_m).

The torque fluctuates often during one working cycle but T_m has the same influence on the actuator as the actual fluctuating torque. The mean torque (T_m) can be calculated using the formula:

$$T_m = \sqrt[3]{\frac{T_1^3 C_1 + T_2^3 C_2 + T_3^3 C_3 + \dots}{C_1 + C_2 + C_3 + \dots}} \quad \text{Nm}$$

T_1, T_2, T_3 , etc. is the constant torque (in Nm) during C_1, C_2, C_3 , etc. fraction of a cycle.

One (1) cycle is identical to a 180° rotation on the output shaft of the actuator. (When the actual working cycle is a few degrees or fractions of a degree, the accumulated number of operations must be calculated in order to reach one 180° cycle for L_{10} calculation).

Acme screw actuators

The L_{10} life of a ball screw can be predicted by the rolling bearing theory and experience.

The life of an acme screw has different characteristics. While the lifetime of a ball screw ends rather suddenly (due to material stresses in the balls) the wear of an acme screw starts from the beginning and continues until final breakdown.

Therefore, when predicting the service life of a rotary actuator incorporating an acme screw, it is necessary to know the ambient temperature, intermittence factor, rotational speed, etc. Always contact SKF whenever you consider acme screw versions.

To calculate the appropriate size of the motor (drive) it is necessary to know the maximum load (torque) that the actuator must handle and at which rotational speed this takes place.

The speed of the drive unit (n_{in}) can be calculated from diagram 1 or with help of this formula.

$$n_{in} = \frac{15 \cdot U}{t_{90^\circ}} \text{ rpm}$$

n_{in} = The speed of the drive unit in rpm (the actuator input speed in order to meet the requested speed on the output shaft.)

t_{90° = Positioning time for a 90° angular movement on the output shaft of the actuator.

U = Gear ratio in actuator.

The input torque needed (T_{in}) can be calculated from diagram 2 or with help of this formula.

$$T_{in} = \frac{T_{out}}{U \cdot \eta_a} \text{ Nm}$$

T_{out} = Maximum output torque (actuator) Nm

U = Gear ratio in actuator

η_a = Efficiency factor (actuator)

Example:

You have chosen a CRAB 30 rotary actuator to operate 600 Nm at maximum, with a speed of 7,5°/s. (7,5°/s equal to 90°/12 s) What torque (Nm) and speed (rpm) must the drive unit produce?

Alt. 1: See diagram 1 and 2.

Alt. 2: Use the formulae

$$\text{Torque}_{(motor)} = \frac{T_{out}}{U \cdot \eta_a} = \frac{600}{88 \cdot 0,75} = 9,09 \text{ Nm}$$

$$\text{Speed}_{(motor)} = \frac{15 \cdot U}{t_{90^\circ}} = \frac{15 \cdot 88}{12} = 110 \text{ rpm}$$

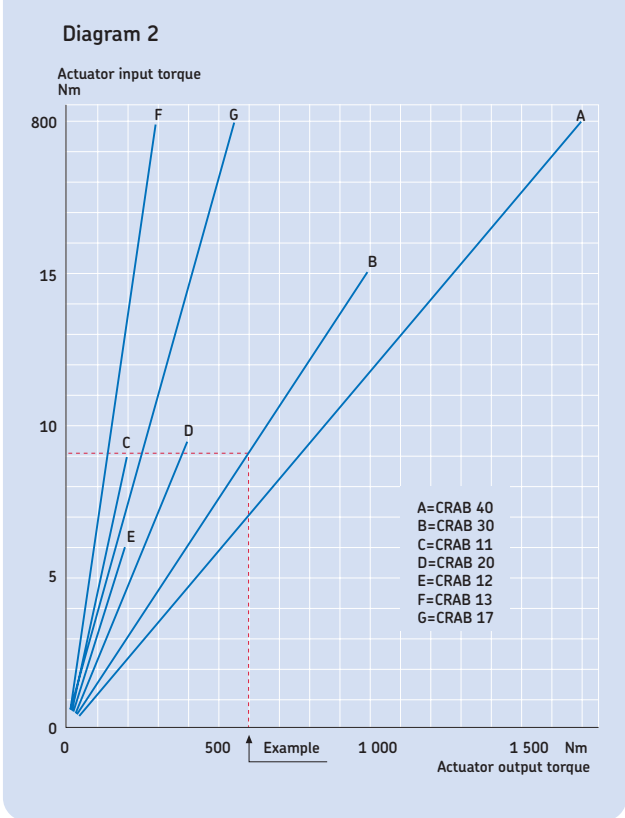
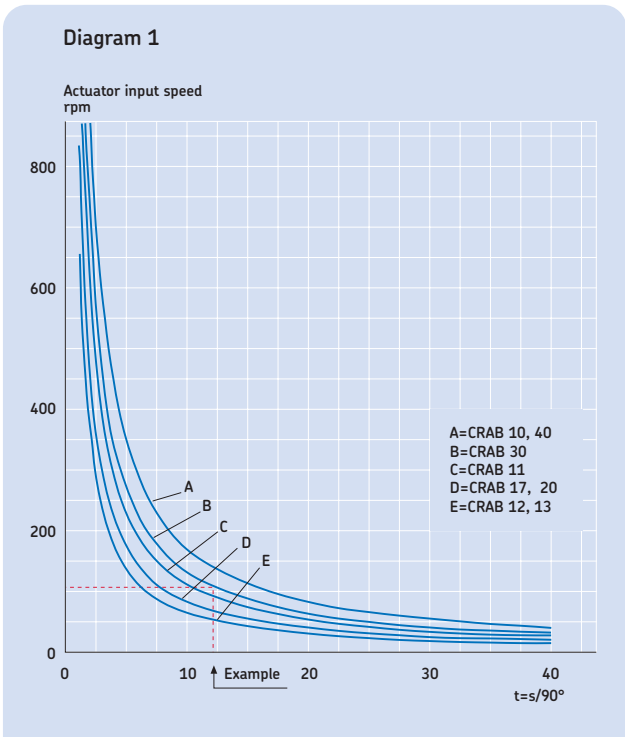

N.B. these diagrams are not valid for CRAB 20, 30, or 40 versions with ACME SCREW. In these cases use the calculations formulae. Always contact SKF whenever you consider these ACME SCREW versions.



Product features

Zero backlash

Rigid construction

Compact design

Symmetric design

Load carrying

Ball screw actuator

Acme screw actuator

Custom-made shaft design

Several motor options

General

User benefits

Precise positioning

High repeatability

Elasticity negligible

Space saving

Flexible installation

Outdoor application

Flexible motor assembly

Output shaft available on both sides

No bearing support required

Tilting moment acceptable

Axial load acceptable

High efficiency

100 % duty factor

Back drive possible

External self-locking

Integrated self-locking

No special adapter required

Quick installation

Cost-effective engineering

Optimized motor choice

Specially-designed control system not required

Maintenance-free operation

Ready to build in component

Rotary actuator selection made easy

With the CRAB 17 modular concept, each actuator can be easily customized for a particular application. The rotary actuator from SKF is modular so that critical components can be interchanged to meet the needs of a special design priority.

The purpose with CRAB 17 is to be small and compact but still be able to produce high torque. As the actuator can withstand high loads it can also serve as a load-bearing element of your design. Special bearing arrangements are not usually required.



Maintenance free modular actuator from SKF

CRAB 17 rotary actuators are maintenance free and sealed for life in an aluminium housing. Four bolts are needed for mounting. The actuators can be used in almost any kind of environment; hot or cold; dry or damp. There is no need to worry about adjustment or maintenance. CRAB 17 is lubricated for life.

Few moving parts combined to a simple, robust construction enables reliable performance for many years of operation.

This is a very flexible actuator, besides the standard designs of the output shaft there are also various possibilities to design the output shaft in accordance with customer specifications.

In the standard range there are a lot of different options of motors, gears and connectors. In many applications there is a need of emergency manoeuvring in the event of power failure. CRAB 17 have several different solutions to offer.



Safety in the distribution of electricity is of great importance all over the world.

Using CRAB 17, major manufactures in high power switching, are able to design reliable motorized remote controlled switches. This automatic switching ensures continuity of supply by bypassing a line fault in the event of failure.

C12C

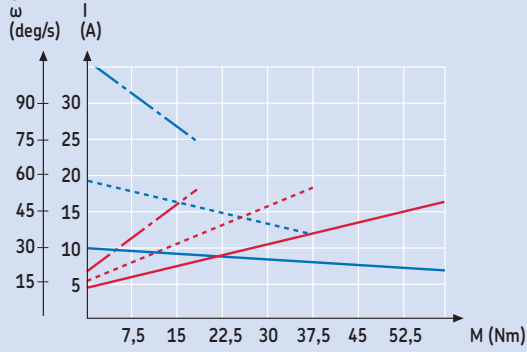

C24C

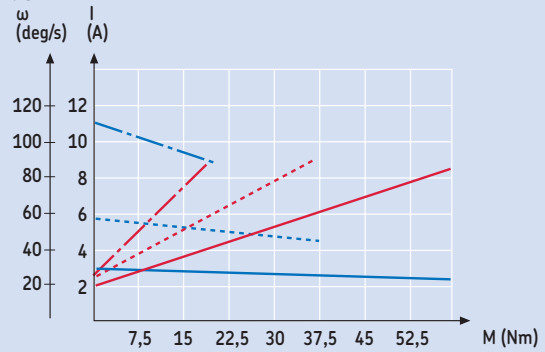

C90C

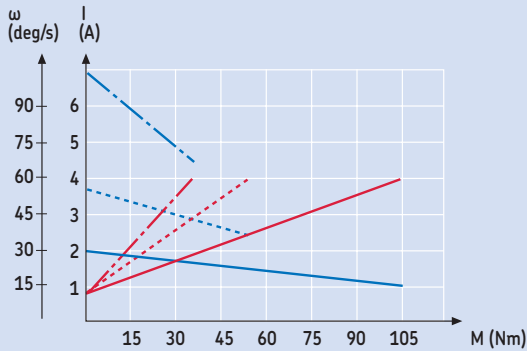

E110 C (25μF)

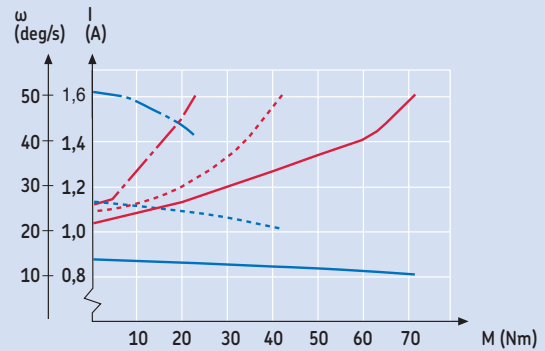

E220C (6μF)

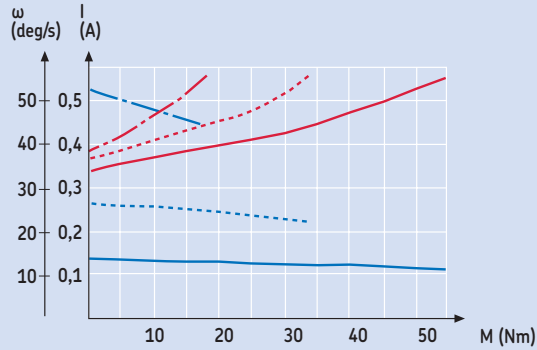

- Gear 1 — I (A)
- ω (deg/s)
- Gear 2 - - - I (A)
- - - ω (deg/s)
- Gear 4 - - - I (A)
- - - ω (deg/s)

Technical data

Max angular working range	∞
Gear ratio	1:52
Max angular speed	180°/s
Efficiency factor	50 %
Max instantaneous output torque	200 Nm
Max axial load	5 000 N
Max tilt moment	100 Nm
Backlash	±0,25°
Start current (E110C/E220C)	2,1/0,8 A
Start torque	≈0,3 Nm
Temperature range	-20 to +60 °C
Weight	3 kg

	C	R	A	B	1	7			X		X		/						
Gear																			
1																			
2																			
4																			
Emergency manoeuvre																			
None																			
Hand crank																			
Release on shaft*																			
Shaft design																			
Solid																			
Solid with key way																			
Hollow with key way																			
Hollow with adapted to limit switch unit																			
Hollow with splines*** (see accessories B)																			
Customized design																			
Limit switches																			
None																			
Switch**																			
Motor direction																			
Rear																			
Upwards																			
Front																			
Downwards																			
Motor assembly																			
Right																			
Left																			
Motor																			
C12C																			
C24C																			
C90C																			
E110C																			
E220C																			
Options for CxxC motors																			
Without cable																			
Encoder																			
Without cover																			
EMC filter																			
Cable 2 m																			
Cable with plug 2 m																			
Cable with plug 1 m																			

* Only standard shaft no 5
 ** Fits standard shaft no 1, 2, 4 and 5
 *** Only in combination with emergency manoeuvre B

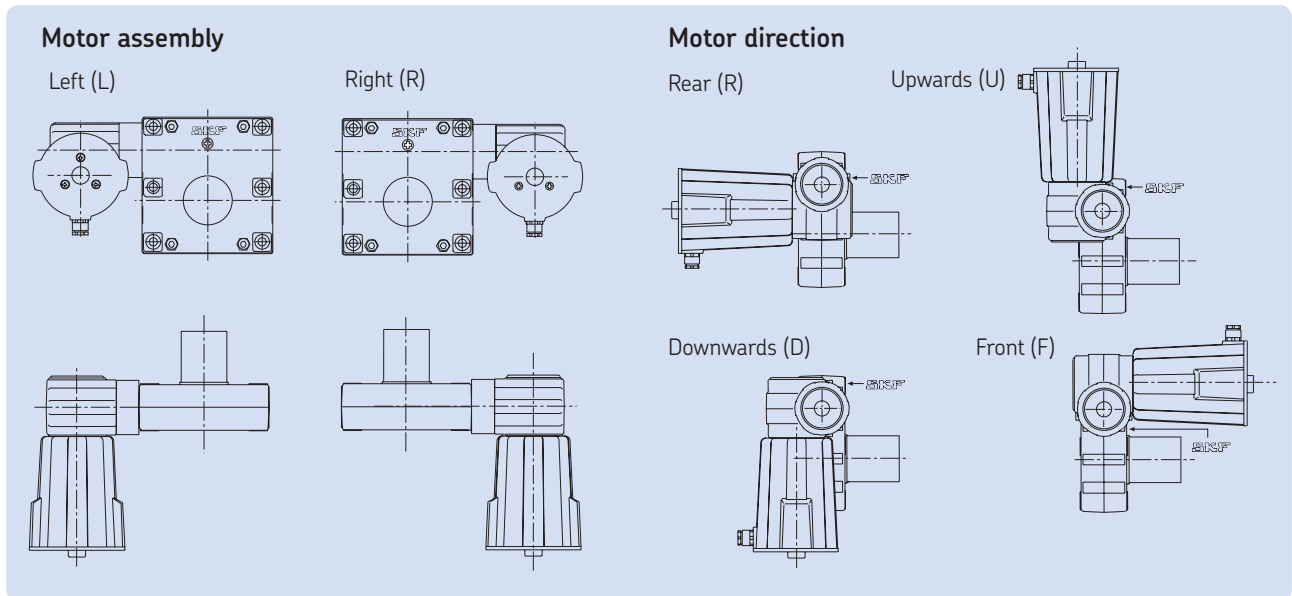

Main measurements

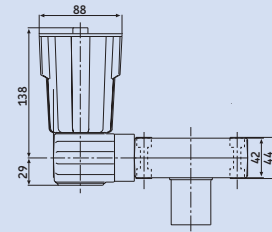
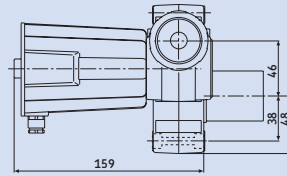
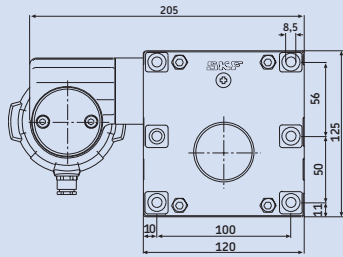

Standard shaft design

1-Solid shaft

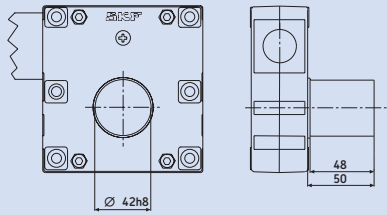

2-Solid shaft with keyway

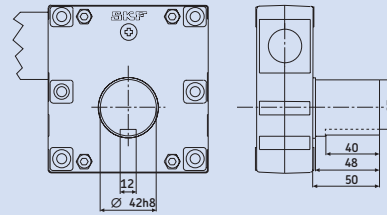

3-Hollow shaft with keyway

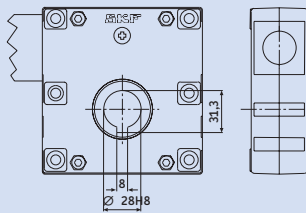

4-Hollow shaft with keyway adapted for limit switch unit

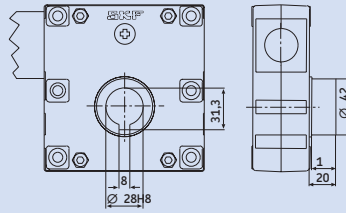

Accessories

S-Limit switch unit

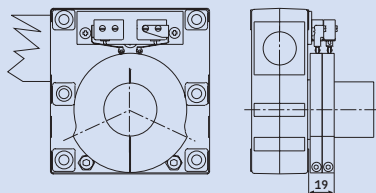

B-Emergency manoeuvring, release on shaft hollow shaft with splines*

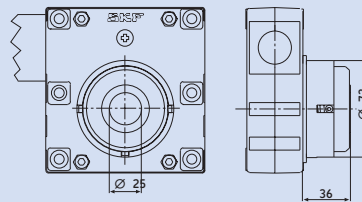

A-Emergency manoeuvring, gearhouse with hand crank

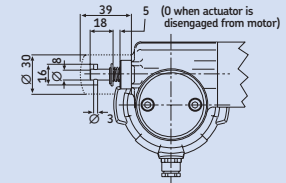

Motor options

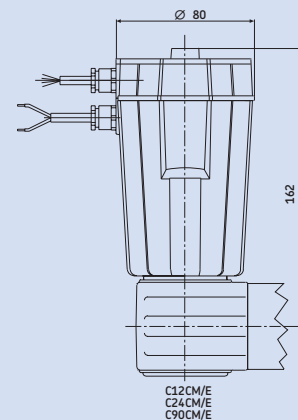
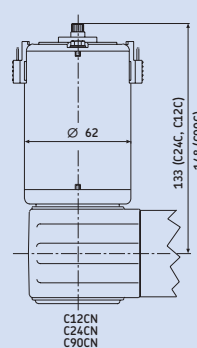
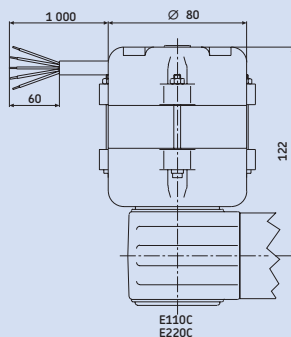

* Splines according to SKF standard.



Contacts

Linear motion from SKF
www.linearmotion.skf.com

Benelux

SKF Multitec Benelux B.V.
Nederland
Tel +31 030 6029 029
Fax +31 030 6029 028

België & Luxembourg

Tel +32 25 024 270
Fax +32 25 027 336
E-mail multitec_benelux@skf.com

Brasil

SKF do Brasil Ltda
Tel +55 11 461 991 114
Fax +55 11 461 991 99
E-mail marketing.skf@skf.com.br

Canada

SKF Canada Limited
Tel +1 416 299 1220
Fax +1 416 299 6548
E-mail www.marketing@skf.ca

Danmark

SKF Multitec
Tel +45 65 92 77 77
Fax +45 65 92 74 77
E-mail customerservice.multitec@skf.com

Deutschland

SKF Linearsysteme GmbH
Tel +49 9721 657 232/233
Fax +49 9721 657 111
E-mail lin.sales@skf.com

Magnetic Elektromotoren GmbH

Tel +49 7622 695 0
Fax +49 7622 695 101
E-mail magnetic.germany@skf.com

España & Portugal

SKF Productos Industriales S.A.
Tel +34 93 377 99 07/-77
Fax +34 93 474 2039/-2156
E-mail prod.ind@skf.com

France

SKF Equipements
Tel +33 1 30 12 73 00
Fax +33 1 30 12 69 09
E-mail equipements.france@skf.com

Italia

SKF Multitec S.p.A.
Tel +39 011 22 49 01
Fax +39 011 22 49 233
E-mail multitec.italy@skf.com

Mexico

SKF de México S.A. de C.V
Tel +52 222 229 4900
Fax +52 222 229 4908
Web www.skf.com.mx

Norge

SKF Multitec
Tel +47 22 90 50 00
Fax +47 22 30 28 14
E-mail customerservice.multitec@skf.com

Schweiz

Magnetic Elektromotoren AG
Tel +41 52 305 02 02
Fax +41 52 305 02 05
E-mail magnetic.switzerland@skf.com

SKF LM&PT

Tel +41 44 825 81 81
Fax +41 44 825 82 82
E-mail skf.schweiz@skf.com

Suomi

SKF Multitec
Tel +358 9 615 00 850
Fax +358 9 615 00 851
E-mail multitec.nordic@skf.com

Sverige

SKF Multitec
Tel +46 42 253 500
Fax +46 42 253 545
E-mail customerservice.multitec@skf.com

U.K.

SKF (UK) Ltd
Tel +44 1582 496 735
Fax +44 1582 496 574
E-mail a&mc@skf.com

USA

SKF Motion Technologies
Tel +1 610 861 3700
Toll free +1 800 541 3624
Fax +1 610 861 3716
E-mail motiontech.usa@skf.com

Österreich

SKF Linearsysteme GmbH
Tel +49 9721 657 232/233
Fax +49 9721 657 111
E-mail: lin.sales@skf.com

Other countries

Fax +41 61 921 37 04
E-mail actuators@skf.com

SKF is a registered trademark of the SKF Group. Jaeger is a trademark of the SKF Group.

© SKF Group 2007

The contents of this publication are the copyright of the publisher and may not be reproduced (even extracts) unless prior written permission is granted. Every care has been taken to ensure the accuracy of the information contained in this publication but no liability can be accepted for any loss or damage whether direct, indirect or consequential arising out of the use of the information contained herein.

