

MAGFORCE WSP

Description

Magforce linear actuators type WSP are specially suitable for industrial applications due to their compact and robust design. The stroke is restricted by internal mechanical stops. Magforce actuators have an integrated friction clutch to protect the actuator and the application from overload. The internal mechanical end stops must not be used as stroke limit. If it cannot be avoided that the actuator runs into the end stops, the use of end switches (accessories or external) is imperative. The motor, however, should be prevented from operating for long periods of time against the end stops. The duty cycle stated below relates to an ambient temperature of +40 °C and an interval operating time of 10 minutes. The technical data mentioned refer to operation under nominal load. A thermal switch incorporated in the motor winding cuts off the power supply at 140 °C thus protecting the motor from overheating and resets itself again after cooling. The standard stroke is 200 mm, but lengths up to 700 mm are available on request, whereby the body length is increased proportionally. With increasing push forces the safety factor decreases. In order to maintain the recommended safety factor of $S=4$ an additional guide bearing can be fitted, which extends the body length by 50 mm.

Electrical Connection

Electrical connections are extremely simple because there are no built-in limit switch. Reversing of the motor is achieved by changing poles via push button or relay. A direct change of direction should be avoided because of the arising inertia forces. The push button or switch must return automatically to the neutral position when it is released so that the motor does not run against the end stops for longer than necessary. Alternatively external limit switches can be supplied on request which switch off the motor in the end positions. For wiring diagram see inside terminal box. Do not connect motors in parallel. They must be connected according to a special diagram.

Installation

The actuator is fixed to the rear clevis and push tube. Turning of the push tube is generally possible. Ensure that the push tube cannot turn and that the load on the push tube is axial only. Side loads on the push tube must be avoided. The push tube must not be subjected to bending loads and motor and levers should be aligned. Make sure that the electric cables are not damaged by squeezing, bending or stretching. Customers must ensure that the cable entry point is tight to guarantee protection class IP54.



Maintenance

The linear actuator has sufficient lubrication reserve and is almost maintenance-free. Only the push tube should be cleaned and lightly greased from time to time. The service life depends very much on the corresponding application (for example, temperature, conditions regarding run, force and cycles, as well as environmental influences) and must be found out in case of need. Defective motors may be repaired only in our factory for safety reasons.

Remark

If our actuators are used for applications where persons could be directly or indirectly endangered, we have to be contacted in order to discuss safety precautions.

Technical data:	Unit	WSP 510	WSP 1030	WSP 1550	WSP 2650
Push/pull force	N	500	1 000	1 500	2 600
Static load	N	6 000	6 000	6 000	6 000
Speed	mm/s	57	19	11	5
Stroke length	mm	100 to 700	100 to 700	100 to 700	100 to 700
Voltage	VAC/50 Hz	1x230	1x230	1x230	1x230
Power consumption	W	220	200	200	230
Current consumption	A	1,1	1,0	1,0	1,1
Duty cycle (SD 10 min.)	%	25	25	25	25
Ambient temperature	°C	-10 to +40	-10 to +40	-10 to +40	-10 to +40
Protection/insulation class	-	I/F	I/F	I/F	I/F
Protection class	IP	54	54	54	54
Weight (with 200 mm stroke)	kg	5,5	5,5	5,5	5,5

Linear actuators MAGFORCE WSP

Special versions

Bellows

As protection against environmental influences such as contamination, dust steam, etc., bellows are available up to a stroke length of 200 mm. These bellows must be ordered together with the actuator as thus the body length is increased by 50 mm, i.e. bellows cannot be fitted later on. They are not necessary as protection against water as our actuators already correspond to protection class IP54. For an extra price a push tube made of stainless steel can be supplied.

Extended motor shaft

For manual operation the actuator can be equipped with an extended motor shaft with flat side. Position and dimensions see drawing.

Special gear box

Besides the standard gear box actuators can be supplied with a gear box with fixing eye turned by 90° or with rear screw fixing.

Accessories

- limit switches 1043,0209
- friction brake for pull/push force 1028,7851
- potentiometer
- additional bushing
- stainless steel push tube
- special voltages

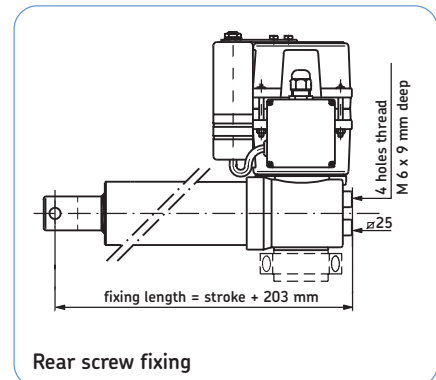
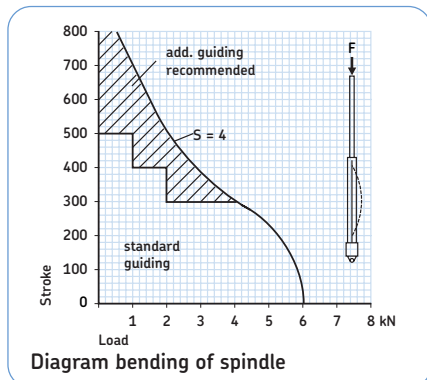
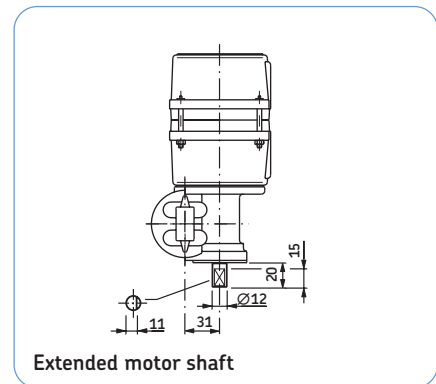
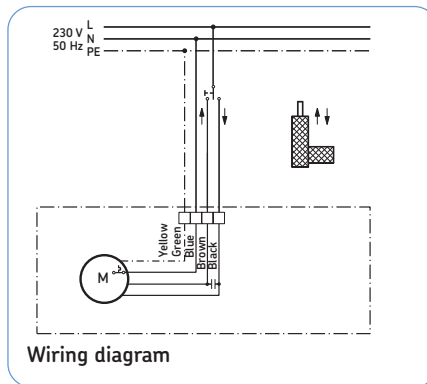

S = safety factor Euler 3

