

# Control unit

## VCU

### Operation

The VCU is a modern control unit for a maximum of five 24 VDC actuators. Very high reliability and long lifetime are achieved by the new internal configuration. The well thought out design of the control unit allows economical customization for special applications. Such modifications are carried out at the factory. Individual parameterization of the motor outputs enables the connection of different types of actuators to the same control unit.

### Single fault safety

In accordance with EN60601-1, special attention has been paid to single fault safety for this control unit. As soon as the control unit detects that an error has occurred, all movements are immediately interrupted, or not carried out. In addition, the leads of an appropriate SKF operating device are also continually checked. In the event of a short circuit in the lead (for example because of the cable being crushed), no movement of the actuators is initiated. These measures ensure a very high level of safety (personal protection).

### Connections

The VCU control unit with built-in power supply is connected to the mains

electricity supply (except for VCU1). It possesses two connections for hand switches, foot switches or other operating devices with HD15 plugs. Optionally up to two external limit switches can be connected to another HD15 plug. There are three resp. five DIN8 (DIN41524) jacks available for the actuators. To achieve IP protection, unused outputs must be closed with blanking plugs. The control unit is protected against outside influences and the accidental pulling-out of the plugs by the security protection cover.



### Locking function

With a suitable operating device it is possible to lock individual control unit functions. Locking occurs in the unit and is transferred to all connected operating devices. Thus it is impossible to bypass the locking function with a second operating device.

### Optional storage battery

For mains-independent operation, the VCU control unit can also be equipped with various storage batteries. The batteries are connected with the unit via a cable, which enables flexible positioning. The charging circuit is located in the battery housing and is optimally adjusted to the respective battery type.

### Overload protection

The VCU control unit transformer is protected against overload by means of a thermal shield. The control unit possesses an individual and a total power cut-off. Individual power cut-off protects the actuator in the event that the current maximum is exceeded which can occur when coming into contact with a stop or through the overloading of an actuator. The total power cut-off protects the control unit against overload if several motors are in operation at the same time. When starting up, the operating manual must always be followed. The user must make provision for applications where there is a risk to personal safety.

Technical data	Units	VCU1	VCU4 VCU5	VCU8 VCU9
Voltage (U <sub>m</sub> )	V	24 DC (22-40)	120 AC +/- 10 %	230 AC +/- 10 %
Frequency	Hz	-	60	50
Current consumption (7 A resp. 18 A)	A	30	2,5, resp. 6,5	1,3, resp. 3,3
Output voltage	VDC	U <sub>m</sub> - 2,2 V @ 3,0 A	24	24
Max. output current	A	30*	7 resp. 18	7 resp. 18
Duty cycle	-	1 min./9 min.	-	-
	intermittent, DC version	-	2 min./18 min.	2 min./18 min.
	intermittent, 7 A version	-	1 min./9 min.	1 min./9 min.
	intermittent, 18 A version	-	2 min.	2 min.
	short time	-	-	-
Ambient temperature	°C	+5 to +40	+5 to +40	+5 to +40
Humidity	%	5 to 85	5 to 85	5 to 85
Degree of protection	IP	X4	X4	X4
Protection class	-	-	VCU4: II; VCU5: I	VCU8: II; VCU9: I
Approvals	EN/UL	EN 60601-1	UL 60601-1	EN 60601-1
Weight (7 A resp. 18 A)	kg	1,2	2,4, resp 3,8	2,4, resp 3,8
Weight incl. optional storage battery	kg	4,2	5,4, resp. 6,8	5,4, resp. 6,8

\*With optional storage battery: 23A

Control unit VCU

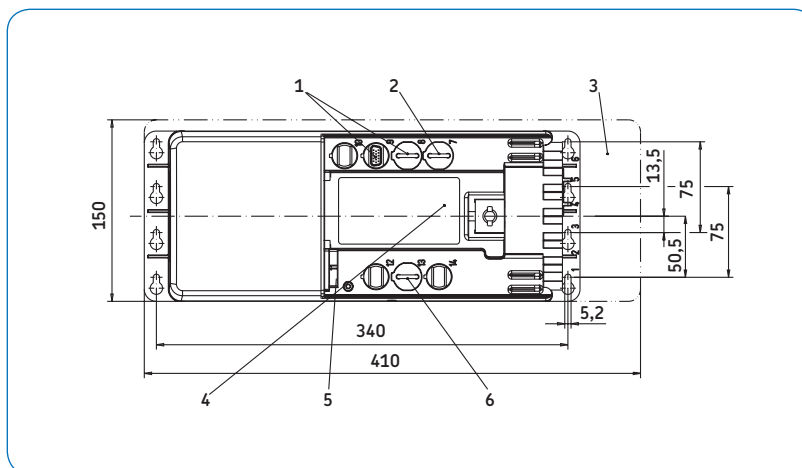
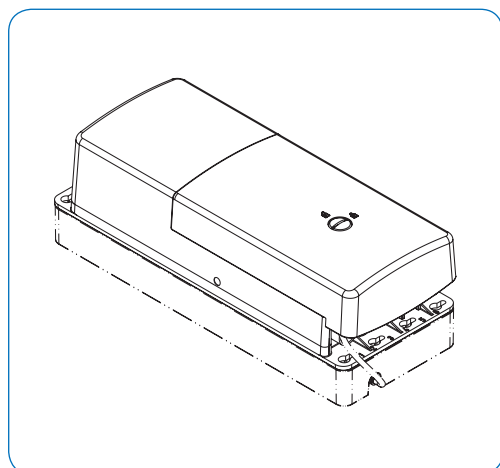
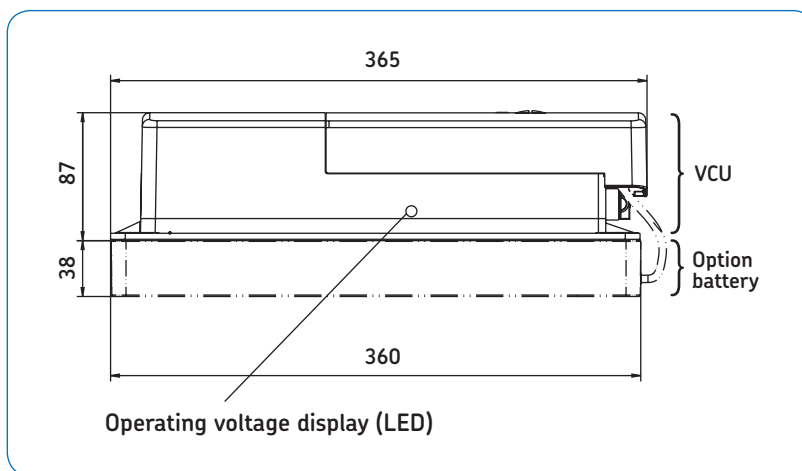
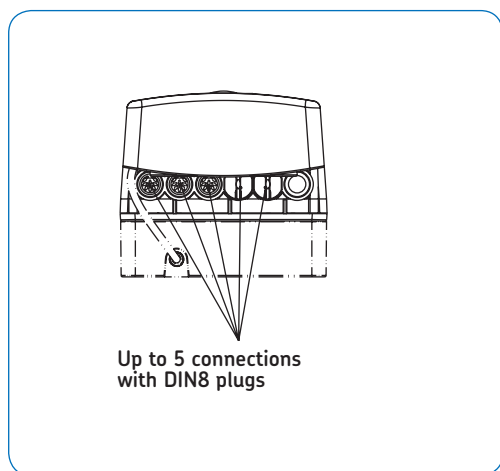

**Connection diagram for optional external limit switches**

Single fault safe wiring requires diodes in series to the switches. NC contacts have to be used to stop a movement; NO contacts are used to start movements. Switch connection data: 50 VDC min., 100 mA min. (eff. switching current approx. 10 mA)

1. Two connections for HD15 operating devices
2. HD15 limit switch connection
3. Additional space for mounting
4. Data plate software
5. Mains connection
6. D-Sub 9 battery connection (optional)

**Pinning of HD15 limit switch**

Function	Pin	Wire colour (ZKA-160627-2500)
24V DC (com)	1	white-yellow
Switch 1	2	brown-green
24 VDC (com)	3	white-green
Switch 2	4	red-blue
24 VDC (com)	5, 7, 9	grey-pink, black, blue
NC	6, 8, 10, 11, 12, 14	violet, red, pink, grey, yellow, brown
20-40 VDC, max. 50 mA	13	green
GND	15	white

**Connection diagram**

