

SKF Linear ball bearings



The SKF Group

The SKF Group is an international industrial corporation of AB SKF Sweden, founded in 1907. Today, the company has some 45 000 employees, runs more than 80 manufacturing facilities and is operating in 130 countries.

Its international network is supported by nearly 20 000 distributors and retailers. SKF is the world leader in the rolling bearing business, with bearings, seals and special steels as its main product areas. In addition, SKF manufactures and sells a wide range of other industrial precision components and products.

SKF Linear Motion

A considerable share of these precision products is manufactured and sold by the SKF Linear Motion division. With some 700 employees, the unit manufactures 3 product lines at 6 manufacturing facilities. One of the division's strengths is its distinct market orientation that is ensured by its 11 specialised sales companies in Europe and North America. In addition, the international SKF network guarantees the worldwide availability of linear motion products and application engineering support.

The Linear Motion product range covers:

- High-performance ball and roller screws
- Linear guidance systems
- Electromechanical actuators

CD-ROM "Designer"

All Linear Motion products are available on this CD, as DWG and DXF files. Thanks to "Designer", you can easily copy the required product drawing into your own design drawing. If you are interested in obtaining a free copy of this CD-ROM, please do not hesitate to contact your local SKF sales organisation.



**Catalogue n° 4182 E / XIV
47173 · 1500 · 2003-08**

Printed in Germany
by Weppert GmbH & Co. KG

© Copyright SKF 1992
The contents of this catalogue are the copyright of the publishers and may not be reproduced (even extracts) unless permission is granted. Every care has been taken to ensure the accuracy of the information contained in this catalogue but no liability can be accepted for any errors or omissions.

Earlier catalogues, the data in which deviate from those given here, are rendered invalid. The right is reserved to make changes necessitated by technological developments.

Introduction
Product Overview

2

Contents

3

LBBR linear ball bearings
LPB linear plain bearings

4

LBBR linear bearing units

8

LBC .. A linear ball bearings
LPA linear plain bearings

14

LBC linear bearing units

23

Shaft carriers

38

Non-driven quadro linear tables

43

Precision shafts

46

Introduction

This catalogue covers SKF linear ball bearings, linear plain bearings and accessories, with which it is possible to construct economic linear guides of particularly simple design for a wide variety of applications. In cases where, for example, load conditions are such that these bearings and units cannot be used, other SKF linear guidance systems are available. Should information regarding these other systems be required, please contact SKF. The necessary information will be sent free of charge and without obligation, and a technical proposal will also be prepared if required. This new "Linear Bearings" catalogue includes linear ball bearings of Series 1 and 3 to ISO 10285, also linear plain bearings of the same dimensions. Series 1 comprises the compact linear ball bearings LBBR as well as linear plain bearings LPBR. The linear ball bearings LBBR are, in addition to the standard version, also available in a corrosion resistant version. Series 1 is complemented by a comprehensive range of linear bearing units. In addition to the single bearing units, with special shaft seals, tandem, duo and quadro units are now included in the range. Series 3

comprises the advanced cylindrical design LBCR .. A and LBCT .. A linear ball bearings as well as the self-aligning LBCT .. A and LBCF .. A varieties. The range is complemented by the LBHT .. A range of linear ball bearings with extra high load carrying capacity.

In order to keep abreast of ever increasing user demands, SKF has fundamentally revised its linear ball bearings of series LBC (ISO series 3). The resultant new linear ball bearings offer distinct advantages over the former LBC series and the linear ball bearings currently available in the market. A particularly important fact is that the new ISO series 3 bearings can now also be supplied in a corrosion-resistant standard version. Moreover, their integral double-lip seal permits 'for-life' lubrication under standard operating conditions.

As a matter of course, the new linear ball bearings are interchangeable with the former LBC series and all linear ball bearings currently available. Also forming part of this size range are the LPAR and LPAT linear plain bearings which appear for the first time in this catalogue. All linear bearing units are

fitted as standard with self aligning linear ball bearings to accommodate misalignment. Other designs can be found in the appropriate tables. The range of shaft carriers has been extended to include a shaft block conforming to the ISO standard. Shafts, which constitute the raceway of linear ball bearings and linear plain bearings are naturally included in the SKF range of shaft guides.

This catalogue is based on current production. The right is reserved to make changes necessitated by technical developments of the products so that the benefits can be passed on to the user without delay. Information from previous catalogs is superseded by the information contained in this edition. In this catalogue the units used are in accordance with the international SI system.

Conditions of delivery and payment are generally based on those ruling at the time of delivery.

Important notice SKF linear ball bearings are coated with a corrosion inhibiting preservative. Before mounting the bearings, they should be suitably lubricated. See also Publication No. 4185E, SKF Linear guide handbook.

Product Overview

Standard

available from stock (changes reserved)

Non-standard

Price and delivery time on request

Linear ball bearing / Linear bearing units											
Designation	ISO Serie I Compact		ISO Serie III Standard								
Type	LBBR	LPBR	LBCD .. A	LBCF .. A	LBHT .. A	LBCR .. A	LBCT .. A	LPAR	LPAT	-	-
Linear bearing ¹⁾ unit	LUHR LUJR	LUHR PB	LUCD LUCE LUND LUNE	LUCF LUNF	LUCT BH	LUCR LUCS	LUCT	LUCR PA	LUCT PA	- LUCR LUCS	LUCT
Flanged unit ¹⁾	-	-	LVCD	-	-	LVCR	-	-	-	LVCR	-
Tandem unit ¹⁾	LTBR	-	LTCD	LTCF	-	LTCR	LTCT	-	-	-	-
Duo unit	LTDR	-	-	-	-	-	-	-	-	-	-
Quadro unit ¹⁾	LQBR	-	LQCD	LQCF	-	LQCR	LQCT	-	-	LQCR	-
Shaft blocks	LSHS	LSHS	LSCS LSNS	- -	- -	LSCS LSNS	- -	LSCS LSNS	- -	LSCS -	- -
Tandem-shaft block	LEBS	-	LEAS	-	-	LEAS	-	-	-	LEAS	-
Shaft supports	- -	- -	- -	LRCB LRCC	LRCB LRCC	- -	LRCB LRCC	- -	LRCB LRCC	- -	LRAB LRAC

¹⁾ Linear bearing units without seals are available on request only.

Contents

LBBR Linear bearings ISO Dimension Series 1	
LBP Linear plain bearing ISO-Dimension Series 1	
LBBR linear ball bearings	4
LPBR linear plain bearing	6
LBBR Linear bearing units ISO Dimension Series 1	
General	8
LUHR/LUJR single linear bearing units with closed housing	10
LTBR Tandem linear bearing units with closed housing	11
LTDR Duo linear bearing units with closed housing	12
LQBR Quadro linear bearing units with closed housing	13
LBC .. A Linear bearings ISO Dimension Series 3	
LPA Linear plain bearing ISO-Dimension Series 3	
General	14
LBCR .. A linear ball bearings, closed design non self-aligning	18
LBCD .. A linear ball bearings, closed design self-aligning	19
LBCT .. A, LBHT .. A linear ball bearings, open design non self-aligning	20
LBCF .. A linear ball bearings, open design self-aligning	21
LPAR, LPAT linear plain bearings, closed and open design	22
LBC Linear bearing units ISO Dimension Series 3	
General	23
LUCR/LUCD Linear bearing units with closed housing	26
LUCS/LUCE Linear bearing units with slotted housing	27
LUCT/LUCF Linear bearing units with open housing	28
LUCT...BH Linear bearing units with open housing and increased load carrying capacity	29
LUND Linear bearing units with closed housing	30
LUNE Linear bearing units with slotted housing	31
LUNF Linear bearing units with	32
LVCR/LVCD Flanged linear bearing units	33
LTCD Tandem linear bearing units with closed housing	34
LTCF Tandem linear bearing units with open housing	35
LQCR/LQCD Quadro linear bearing units with closed housing	36
LQCF Quadro linear bearing units with open housing	37
Shaft carriers	
General	38
LSCS Shaft blocks	39
LSNS/LSHS Shaft blocks	40
LEAS/LEBS Tandem shaft blocks	41
LRCB/LRCC Shaft supports	42
Non-driven quadro linear tables	
General	43
LZBU Quadro linear tables with closed housing	44
LZAU Quadro linear tables with open housing	44
Precision shafts	
General	46
LJM/LJT Precision shafts	50

LBBR linear ball bearings/LPB linear plain bearings

LBBR linear ball bearings

The recently developed compact LBBR linear ball bearing is of a patented design. The bearing comprises a plastic cage carrying hardened steel raceway segments and guiding the ball sets. The bearing conforms to dimension series 1 of ISO 10285. The LBBR raceway segments have been designed to maximise the length of the load carrying zone. A high load bearing capacity is therefore possible with a resulting long service life. The design of the plastic cage is entirely new and has been optimised. The key feature is that all the balls in the bearing run on the same pitch circle diameter which allows ball recirculation to take place smoothly with no

resulting cage loads. Ball diameter can be maximised with this design of cage with implications not only for load capacity and life but also on running quality.

The seal design on this new bearing type has also been improved. The sealed variant is fitted with integral double lip seals. These seals have an inner lip that prevents escape of lubricant from within the bearing and an external lip to wipe the shaft surface as the bearing moves. The unsealed bearing is fitted with non-contacting shields that protect against major contamination from the bearing. The linear ball bearings LBBR, need not be secured axially in the housing provided the housing bore is correct.

Stainless

The application of linear bearings has been extended by this new type with the introduction of a corrosion resistant variant Raceway segments and balls can be specified in high alloy stainless steel by adding the suffix HV6 to the designation, e.g. LBBR 16-2LS/HV6. In combination with our stainless steel shafts, the linear ball bearing LBBR thus offers the possibility of realising a design completely of stainless steel.



LBBR linear ball bearings

LBBR linear ball bearings

with raceway plates

F_w 3-50 mm

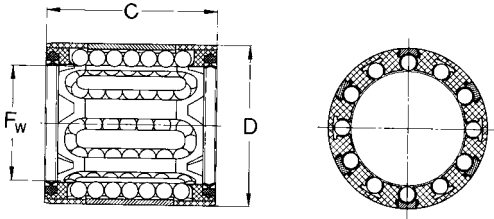

Linear ball bearing LBBR
with double lip seal

Dimensions			No. of ball rows	Basic load ratings		Mass	Designations			
F_w	D	C		dyn. C	stat. C_0		Linear ball bearings standard design	with 2 double lip seals	stainless steel standard design	with 2 double lip seals
mm	—	—	N		kg					
3	7	10	4	60	44	0,0007	LBBR 3	LBBR 3-2LS	LBBR 3/HV6	LBBR 3-2LS/HV6
4	8	12	4	75	60	0,001	LBBR 4	LBBR 4-2LS	LBBR 4/HV6	LBBR 4-2LS/HV6
5	10	15	4	170	129	0,002	LBBR 5	LBBR 5-2LS	LBBR 5/HV6	LBBR 5-2LS/HV6
6	12	22 ¹⁾	4	335	270	0,006	LBBR 6A	LBBR 6A-2LS	LBBR 6A/HV6	LBBR 6A-2LS/HV6
8	15	24	4	490	355	0,007	LBBR 8	LBBR 8-2LS	LBBR 8/HV6	LBBR 8-2LS/HV6
10	17	26	5	585	415	0,011	LBBR 10	LBBR 10-2LS	LBBR 10/HV6	LBBR 10-2LS/HV6
12	19	28	5	695	510	0,012	LBBR 12	LBBR 12-2LS	LBBR 12/HV6	LBBR 12-2LS/HV6
14	21	28	5	710	530	0,013	LBBR 14	LBBR 14-2LS	LBBR 14/HV6	LBBR 14-2LS/HV6
16	24	30	5	930	630	0,018	LBBR 16	LBBR 16-2LS	LBBR 16/HV6	LBBR 16-2LS/HV6
20	28	30	6	1 160	800	0,021	LBBR 20	LBBR 20-2LS	LBBR 20/HV6	LBBR 20-2LS/HV6
25	35	40	7	2 120	1 560	0,047	LBBR 25	LBBR 25-2LS	LBBR 25/HV6	LBBR 25-2LS/HV6
30	40	50	8	3 150	2 700	0,07	LBBR 30	LBBR 30-2LS	LBBR 30/HV6	LBBR 30-2LS/HV6
40	52	60	8	5 500	4 500	0,130	LBBR 40	LBBR 40-2LS	LBBR 40/HV6	LBBR 40-2LS/HV6
50	62	70	9	6 950	6 300	0,18	LBBR 50	LBBR 50-2LS	LBBR 50/HV6	LBBR 50-2LS/HV6

¹⁾ Width 22 does not correspond to series 1 in ISO standard 10285.

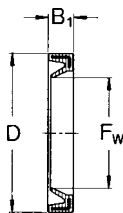

Appropriate special seals			
Dimensions		Designations	
F_w	D	B_1	
mm	—	—	
6	12	2	SP-6x12x2
8	15	3	SP-8x15x3
10	17	3	SP-10x17x3
12	19	3	SP-12x19x3
14	21	3	SP-14x21x3
16	24	3	SP-16x24x3
20	28	4	SP-20x28x4

Appropriate special seals			
Dimensions		Designations	
F_w	D	B_1	
mm	—	—	
25	35	4	SP-25x35x4
30	40	4	SP-30x40x4
40	52	5	SP-40x52x5
50	62	5	SP-50x62x5

LPBR linear plain bearings

LPBR linear plain bearings have the same dimensions as the LBBR linear ball bearings described above. In selecting the most suitable slide material (polyacetal with polyethylene) special attention was given to the stick-slip-free characteristics. Furthermore the SKF linear plain bearings require little maintenance and show excellent performance under breakdown conditions. They have high static load carrying capacity and are resistant to shock loads.

The use of lubricant is recommended after installation to allow improved running-in even when non-lubricated operation is desired.

These bearings are intended for use in those applications where linear ball bearings cannot be used due to extraordinary operating conditions. This is the case especially when the bearing arrangement is subjected to heavy shock loads or vibrations or to high accelerations and speeds in the unloaded state.

Under these operating conditions linear plain bearings are the better choice compared with linear ball bearings, however, increased friction must be expected.



LPBR linear plain bearings

closed design

F_w 12-50 mm

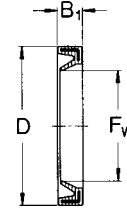
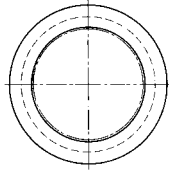
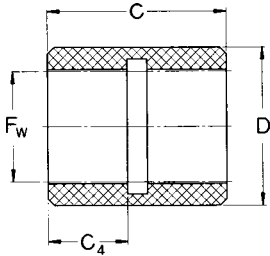

Linear plain bearing LPBR

Special seal

Dimensions				Basic road ratings			Mass	Designation	Appropriate special seals			
P_w	D	C	C4	dyn. at		stat.	—	Linear plain bearing	Dimensions			Designation
				0,1 m/s	4 m/s	C			C	C ₀	F_w	
mm				N			kg	mm				
12	19,19	28	10	965	24	3 350	0,006	LPBR 12	12	19	3	G 12x19x3
16	24,23	30	12	1 530	38	5 400	0,009	LPBR 16	16	24	3	G 16x24x3
20	28,24	30	13	2 080	52	7 350	0,011	LPBR 20	20	28	4	G 20x28x4
25	35,25	40	17	3 400	85	12 000	0,024	LPBR 25	25	35	4	G 25x35x4
30	40,27	50	20	4 800	120	17 000	0,033	LPBR 30	30	40	4	G 30x40x4
40	52,32	60	24	7 650	193	27 000	0,063	LPBR 40	40	52	5	G 40x52x5
50	62,35	70	27	10 800	270	38 000	0,088	LPBR 50	50	62	5	G 50x62x5

Other sizes and dimensions are available on request.

* Note

The outside diameter tolerance of the linear ball bearings and linear plain bearings is such that no additional axial location is required when the bearings are fitted into a bore with a tolerance of J7 or J6.

Linear bearing units with LBBR linear bearings or LPB linear plain bearings

Linear bearing units incorporating bearings of ISO series 1 are available for unsupported applications in closed design.

These cost-effective bearing units are extremely space-saving thanks to the compactness of the design, but they can nevertheless accommodate loads exceeding 25 000 N (e.g. LQBR 50-2LS; see also page 13).

The new double lip seals fitted to the LBBR bearings enable these units to run without relubrication,

under normal operating conditions. On special request, it is possible to buy pre-greased bearings. This guarantees that the right amount of grease is inserted and that the grease is properly distributed in the bearing.

The systems are available in the length required by the customer. See also the chapter „Precision shafts“, page 46 ff. Please note that the maximum permissible angular misalignment is 15 minutes of arc. For

the influence on the load carrying capacity, see diagram 9 on page 18 in the technical handbook.

A corrosion resistant alternative consists of aluminium housings with stainless steel linear ball bearings such as LBBR 20-2LS/HV6 or aluminium housings fitted with plain bearings.

For such applications the shafts are made of stainless steel, normally X90 CrMoV18.



Linear bearing units with LBBR linear bearings or LPB linear plain bearings

LUHR/LUJR linear bearing units

These linear bearing units consist of a housing of extruded light alloy and the compact LBBR linear ball bearings or the LPBR linear plain bearings of similar dimensions.

The LUHR design for shaft diameters from 12 to 50 mm are available fitted as standard with LBBR linear ball bearings with or without integrated seals or with LPBR (Designation LUHR..PB) linear plain bearings.

For severe operating conditions, notably in the presence of high levels of contamination, the extended LUJR linear bearing units have been included in the range. These incorporate LBBR linear ball bearings and two G type seals.

LUHR and LUJR linear bearing units cannot be relubricated. The

previous linear bearing units LUBR and LUER are no longer shown in the catalogue, but are still available on request.

LTBR tandem linear bearing units

These comprise a one-piece extruded aluminium housing and two LBBR linear ball bearings mounted one behind the other. These units are fitted with seals as standard and can not be relubricated. They are particularly suitable to tables or slides of any width.

LTDR duo linear bearing units

The LTDR units are characterised by the fitting of two LBBR-2LS linear ball bearing units in parallel in an aluminium housing. The separation

between the bearings, and the duo configuration permit easy fitting of a linear drive.

LQBR quadro linear bearing units

Four LBBR linear ball bearings are located in an aluminium housing. The unit is sealed and the bearings are spaced sufficiently to permit the fitting of an appropriate linear drive.

Duo and quadro linear bearing units based on LBBR linear ball bearings can be used to make compact, simple table configurations. For suitable shaft blocks (LEBS), see page 41.



LUHR and LUJR linear ball bearing units

with closed housing and LBBR linear ball bearings

F_w 12-50 mm

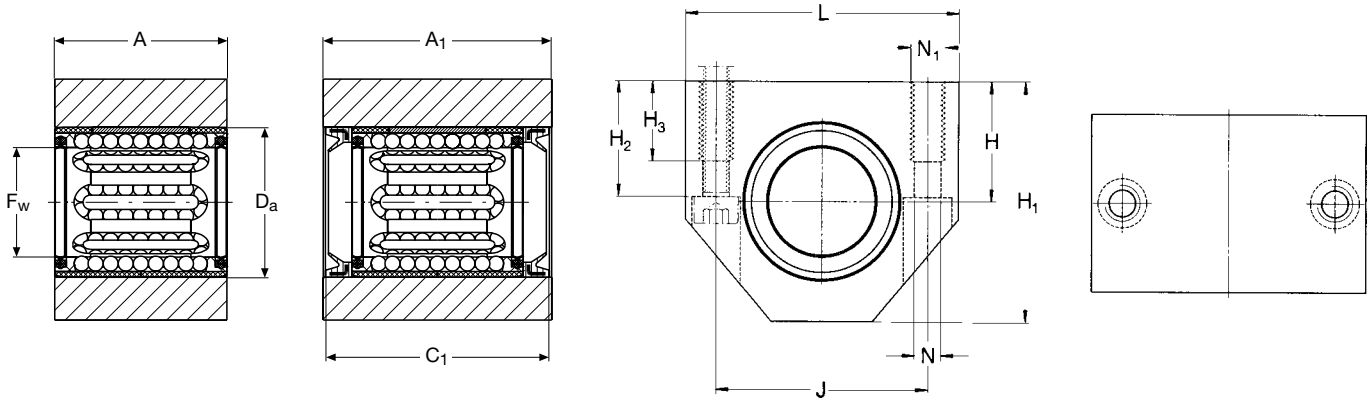

LUHR linear bearing unit
with integral double
lip seal

LUJR linear bearing unit
with shaft seals

Dimensions														Basic load ratings		Mass		Designations		
F_w	A	A_1	C_1	D_a	H	H_1	H_2	H_3	L	J	$N^{2)}$	$N_1^{2)}$	C	stat. C_0	Design LUHR LUJR	Linear bearing unit ¹⁾ without seal	with double lip seals	with shaft seal		
mm												—	N	kg						
12	28	35	34	19	17	33	16	11	40	29	4,3	M 5	695	510	0,08 0,10	LUHR 12	LUHR 12-2LS	LUJR 12		
16	30	37	36	24	19	38	18	11	45	34	4,3	M 5	930	630	0,10 0,12	LUHR 16	LUHR 16-2LS	LUJR 16		
20	30	39	38	28	23	45	22	13	53	40	5,3	M 6	1 160	800	0,14 0,18	LUHR 20	LUHR 20-2LS	LUJR 20		
25	40	49	48	35	27	54	26	18	62	48	6,6	M 8	2 120	1 560	0,25 0,30	LUHR 25	LUHR 25-2LS	LUJR 25		
30	50	59	58	40	30	60	29	18	67	53	6,6	M 8	3 150	2 700	0,37 0,44	LUHR 30	LUHR 30-2LS	LUJR 30		
40	60	71	70	52	39	76	38	22	87	69	8,4	M 10	5 500	4 500	0,74 0,86	LUHR 40	LUHR 40-2LS	LUJR 40		
50	70	81	80	62	47	92	46	26	103	82	10,5	M 12	6 950	6 300	1,19 1,37	LUHR 50	LUHR 50-2LS	LUJR 50		

The previous linear bearing units LUBR and LUER are no longer shown in the catalogue, but are still available on request. For suitable shaft blocks for these bearing units, designation LSHS, see page 40 of this catalogue.

¹⁾ Linear bearing units of the LUHR design are also available fitted with LPBR linear plain bearings.
Designations: e. g. LUHR 20 PB.

²⁾ For screws with internal hexagon to DIN 912/ISO 4762.

LTBR tandem linear bearing units
with closed housing and LBBR linear ball bearings
 F_w 12-50 mm

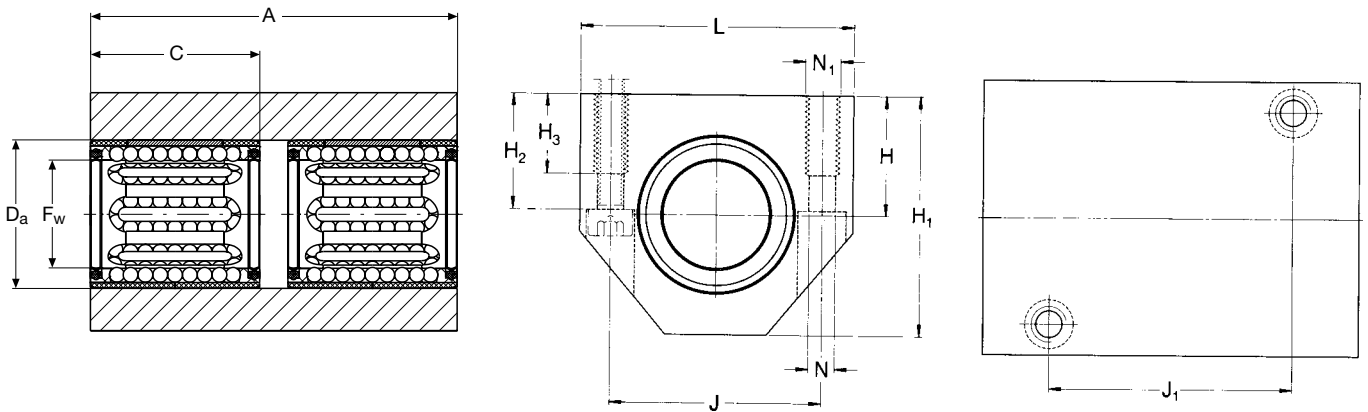

LTBR linear bearing unit
with integral double lip seals

Dimensions													Basic load ratings		Mass	Designations
F_w	A	C	D_a	H	H_1	H_2	H_3	J	J_1	L	$N^{1)}$	$N_1^{1)}$	dyn. C	stat. C_0	kg	Linear bearing unit with double lip seals
mm													—	N	kg	
12	60	28	19	17	33	16	11	29	35	40	4,3	M 5	1 140	1 020	0,17	LTBR 12-2LS
16	65	30	24	19	38	18	11	34	40	45	4,3	M 5	1 530	1 270	0,22	LTBR 16-2LS
20	65	30	28	23	45	22	13	40	45	53	5,3	M 6	1 900	1 600	0,31	LTBR 20-2LS
25	85	40	35	27	54	26	18	48	55	62	6,6	M 8	3 450	3 150	0,54	LTBR 25-2LS
30	105	50	40	30	60	29	18	53	70	67	6,6	M 8	5 200	5 400	0,80	LTBR 30-2LS
40	125	60	52	39	76	38	22	69	85	87	8,4	M 10	9 000	9 000	1,57	LTBR 40-2LS
50	145	70	62	47	92	46	26	82	100	103	10,5	M 12	11 400	12 700	2,51	LTBR 50-2LS

For suitable shaft blocks for these bearing units, designation LSHS, see page 40 of this catalogue.

¹⁾ For screws with internal hexagon to DIN 912 / ISO 4762.

LTDR Duo linear bearing units
with closed housing and LBBR linear ball bearing
F_w 12-50 mm

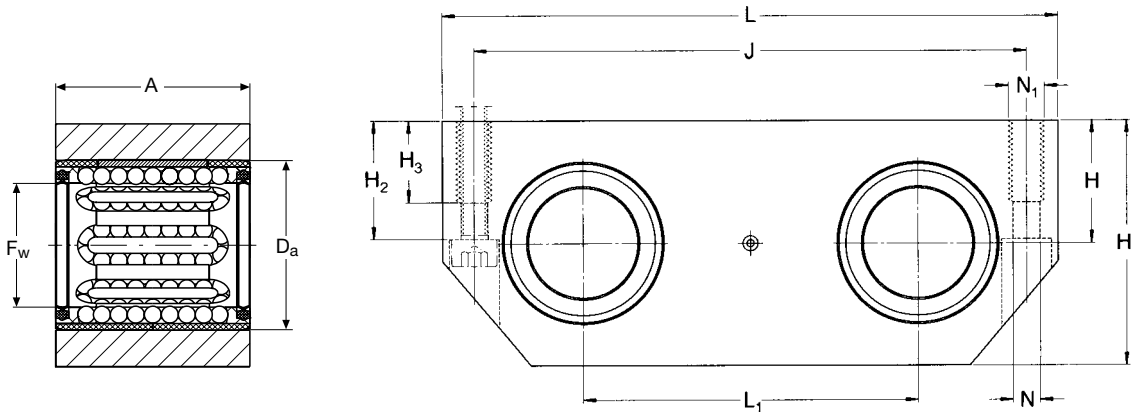

LDTR linear bearing unit
with integral double lip seals

Dimensions												Basic load ratings		Mass	Designations
F _w	A	D _a	H	H ₁	H ₂	H ₃	J	L	L ₁	N ¹⁾	N ₁ ¹⁾	dyn C	stat. C ₀	kg	Linear bearing unit with double lip seals
mm												—	N	kg	—
12	28	19	15	30	14	11	69	80	40	4,3	M 5	1 140	1 020	0,15	LTDR 12-2LS
16	30	24	17,5	35	16,5	11	86	96	52	4,3	M 5	1 530	1 270	0,22	LTDR 16-2LS
20	30	28	20	40	19	13	103	115	63	5,3	M 6	1 900	1 600	0,30	LTDR 20-2LS
25	40	35	25	50	24	18	123	136	75	6,6	M 8	3 450	3 150	0,58	LTDR 25-2LS
30	50	40	28	56	27	18	133	146	80	6,6	M 8	5 200	5 400	0,85	LTDR 30-2LS
40	60	52	35	70	34	22	166	184	97	8,4	M 10	9 000	9 000	1,56	LTDR 40-2LS
50	70	62	40	80	39	26	189	210	107	10,5	M 12	11 400	12 700	2,21	LTDR 50-2LS

For suitable shaft blocks for these bearing units, short designation LEBS..A, see page 41 of this catalogue.

¹⁾ For screws with internal hexagon to DIN 912 / ISO 4762 at the centre (0,5 A) of the linear bearing unit.

LQBR Quadro linear bearing units
with closed housing and LBBR linear ball bearing
F_w 12-50 mm

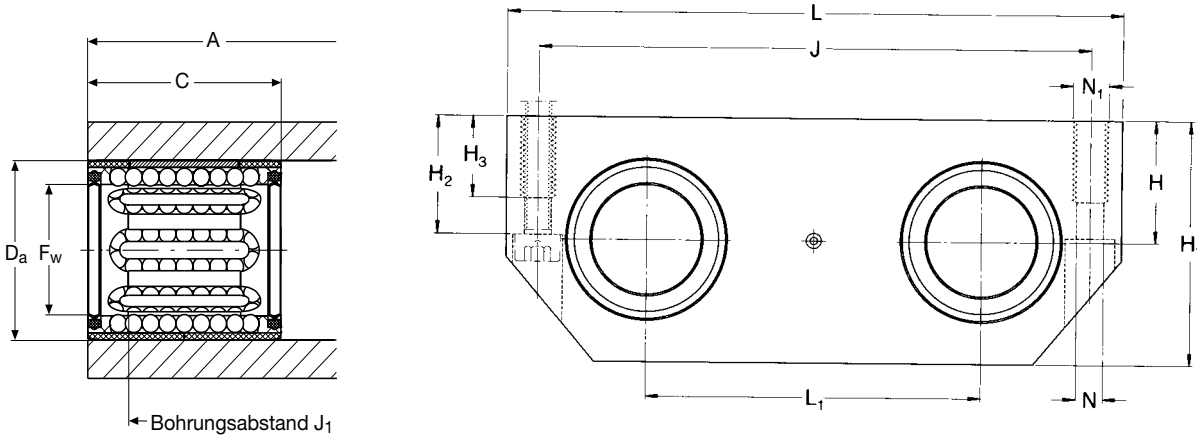

LQBR linear bearing unit
with integral double lip seals

Dimensions											Basic load ratings		Mass	Designations			
F _w	A	C	D _a	H ±0,01	H ₁	H ₂	H ₃	J	J ₁	L	L ₁	N ¹⁾	N ₁ ¹⁾	dyn. C	stat. C ₀	kg	Linear ball bearing unit with double lip seals
mm													—	N	kg	—	
12	70	28	19	15	30	14	11	69	59	80	40	4,3	M 5	1 860	2 040	0,38	LQBR 12-2LS
16	80	30	24	17,5	35	16,5	11	86	70	96	52	4,3	M 5	2 500	2 550	0,57	LQBR 16-2LS
20	85	30	28	20	40	19	13	103	73	115	63	5,3	M 6	3 100	3 200	0,82	LQBR 20-2LS
25	100	40	35	25	50	24	18	123	87	136	75	6,6	M 8	5 600	6 300	1,43	LQBR 25-2LS
30	130	50	40	28	56	27	18	133	117	146	80	6,6	M 8	8 500	10 800	2,15	LQBR 30-2LS
40	150	60	52	35	70	34	22	166	132	184	97	8,4	M 10	14 600	18 000	3,83	LQBR 40-2LS
50	175	70	62	40	80	39	26	189	154	210	107	10,5	M 12	18 600	25 500	5,40	LQBR 50-2LS

For suitable shaft blocks for these bearing units, designation LEBS..A, see page 41 of this catalogue.

¹⁾ For 4 screws with internal hexagon to DIN 912 / ISO 4762.

LBC .. A/LBH .. A linear ball bearings • LPA linear plain bearings

In order to keep abreast of ever increasing user demands, SKF Linear-systeme GmbH has fundamentally revised its linear ball bearings of series LBC (ISO series 3).

The resultant new linear ball bearings offer distinct advantages over the former LBC series and the linear ball bearings currently available in the market. A particularly important fact is that the new ISO series 3 bearings can now also be supplied in a corrosion-resistant standard version. Moreover, their integral double-lip seal permits 'for-life' lubrication under standard operating conditions.

As a matter of course, the new linear ball bearings are interchangeable with the former LBC series and all linear ball bearings currently available. LBC .. A

linear ball bearings are available for shaft diameters from 5 to 80 mm. They are characterised by high load carrying capacity. As with all SKF linear ball bearings, they are available with a choice of shields or seals. LBC .. A linear ball bearings are, in general, designed for grease lubrication. The cage is provided with a through-bored radial hole which permits the attachment of a grease nipple to provide longitudinal and axial location. Grease may be applied direct onto the shaft through this hole. For the relubrication of LBHT .. A linear ball bearings described on this page, the housing must be provided with a grease distribution channel in the bore. The grease is then forced onto the raceway between the load carrying plates.

Information on the location of these attachment holes and grease nipples is shown on pages 16 and 17 of this catalogue.

Stainless

The application of linear bearings has been extended by this new type with the introduction of a corrosion resistant variant Raceway segments and balls can be specified in high alloy stainless steel by adding the suffix HV6 to the designation, e.g. LBCR 16A-2LS/HV6. In combination with our stainless steel shafts, the linear ball bearing LBC .. A thus offers the possibility of realising a design completely of stainless steel.

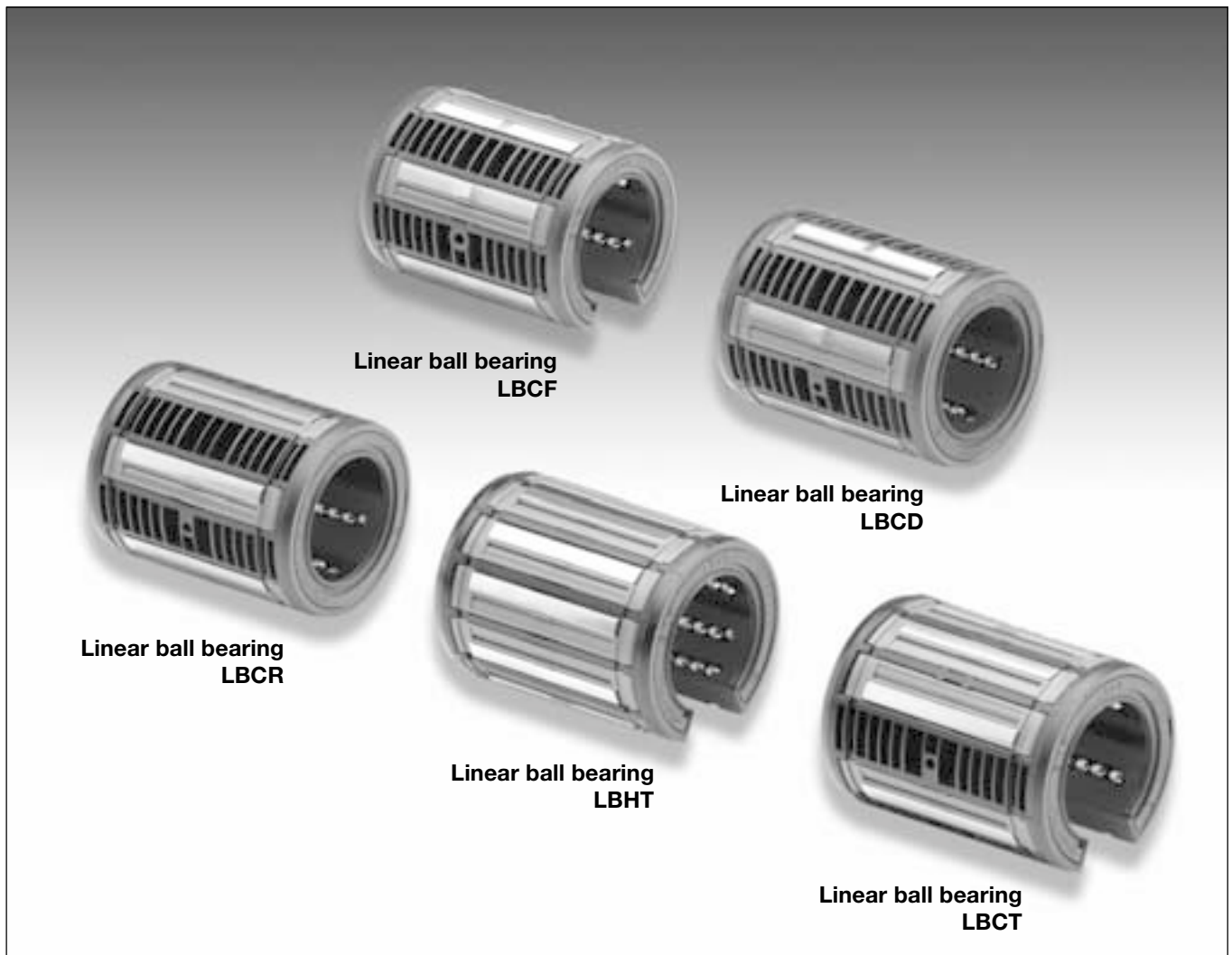

LBCR .. A linear ball bearings

LBCR .. A linear ball bearings comprise a cage in which the balls are guided, together with the raceway segments and the seals or shields. By virtue of their exceptionally long track length and the machined raceway osculation they are able to accommodate heavy loads. LBCR .. A linear ball bearings, with their optimised raceway segments and position for maximum load carrying capacity, can be mounted in closed as well as adjustable housings. When these bearings are mounted in a closed housing, the tolerance of the inscribed diameter of the ball set and hence the operating clearance is determined by the tolerance of the housing bore. When mounted in slotted housings the linear guides can be adjusted to the particular application, to provide either operating clearance or preload. LBCR .. A linear ball bearings must be located in axial direction.

LBCD .. A linear ball bearings

The LBCD .. A linear ball bearing is a variant of the LBCR .. A design. The main characteristic is a self-aligning capability which allows tilting of the race way segment through an angle of ± 30 minutes of arc, thus compensating automatically for alignment errors which may be caused by inaccuracies in fitting or manufacturing (housing bore diameter) or by significant bending of unsupported shafts. The self-aligning qualities of these bearings cannot however compensate for two non-parallel shafts in an assembly. Tilting of the bearing is achieved through a spherical elevation ground at the centre of the raceway segment. The diameter of the cage is also reduced inside the housing, so ensuring that the bearing- and especially the shield or seals - remains concentric with the shaft. All other characteristics of the LBCR .. A linear ball bearings are also valid for the self-aligning LBCD .. A

design. LBCD linear ball bearings must always be firmly located in the axial direction.

LBCT .. A and LBHT .. A linear ball bearings

The open LBCT .. A and LBHT .. A linear ball bearings differ from the LBCR .. A bearings in that a sector has been cut away from the cage and the shields or seals. This allows the shaft to be supported at several positions or along its whole length, so that the accuracy of guidance cannot be affected by any shaft bending. The open design of the LBCT .. A linear ball bearings means that one raceway is absent. The carrying capacity in the main loading direction is however not reduced to any significant extent. In comparison with the LBCT .. A design, the LBHT .. A linear ball bearings have been optimised in terms of the number of raceway segments and hence the load carrying capacity. They are suitable for shaft diameters from 20 to 50 mm. SKF LBCT .. A and LBHT .. A linear ball bearings have an important advantage compared with other open linear ball bearings. They are protected against contaminants by an axial lip in the cage at each side of the opening, which acts as a gap-type seal against the shaft. Open LBCT .. A/LBHT .. A linear ball bearings must always be located in the axial and turning direction.

LBCF .. A linear ball bearings

For the open linear ball bearings of the LBCT .. A design, a self-aligning version similar to the LBCD .. A design is available. Here, the design advantages of the open LBCT .. A bearings are enhanced through the added self-alignment capability. LBCF .. A linear ball bearings must always be securely located in the axial and turning direction.

LPAR and LPAT linear plain bearings

These linear plain bearings have the same external dimensions as those of the LBA/LBC linear ball bearings. Technical details are as shown on page 6 under LPBR linear plain bearings. These bearings are available in diameters from 5 to 80 mm (LPAR) and from 12 to 80 mm (LPAT) and do not have shields. All variants, except for LPAR 5 and 8 can be relubricated. Facilities for location and securing are similar to those for the LBC linear ball bearings but additional axial locating by retaining rings necessary.

Axial and turning stops for LBC .. A linear ball bearings and LPA linear plain bearings

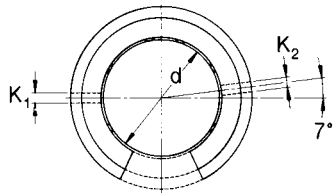

Design 1

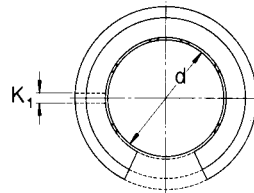

Design 2

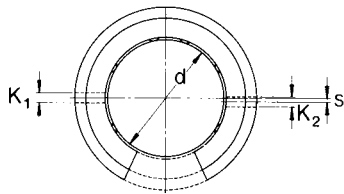

Design 3

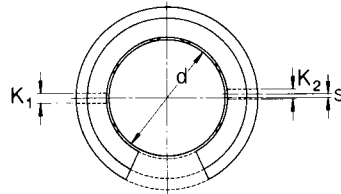

Design 4

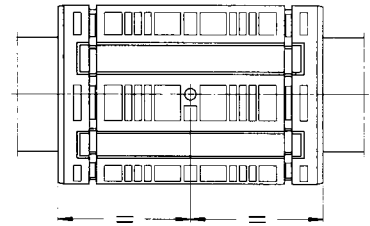

Dimensions				Design ¹⁾	Appropriate grease nipples ²⁾	Grub screws ³⁾	Pins ⁴⁾
d	K ₁	K ₂	s				Diameter
mm				—			mm
12	3,0	3,0	-	1	VN-LHC 20	M 4	3
16	3,0	-	-	2	VN-LHC 20	M 4	3
20	3,0	-	-	2	VN-LHC 20	M 4	3
25	3,5	3,0	1,5	3	VN-LHC 40	M 5	3 / 3,5
30	3,5	3,0	2	4	VN-LHC 40	M 5	3 / 3,5
40	3,5	3,0	1,5	4	VN-LHC 40	M 5	3 / 3,5
50	4,5	5,0	2,5	4	VN-LHC 50	M 6	5 / 4,5
60	6,0	2,5	5	4	VN-LHC 80	M 8	6 ⁵⁾
80	8,0	2,5	5	4	VN-LHC 80	M 8	8 ⁵⁾

¹⁾ All linear plain bearings of Design 2

²⁾ Recommendations for holes to take grease nipples: see page 17.

³⁾ Grub screws to DIN 417 and ISO 7435 or DIN 915 and ISO 4028.

⁴⁾ Straight pins to DIN 7, slotted pins to DIN 1481 or grooved pins to DIN 1470 and DIN 1471.

⁵⁾ Grub screw to DIN 551 / ISO 4766 or DIN 913 / ISO 4026.

Axial and turning stops for LBHT .. A linear ball bearings

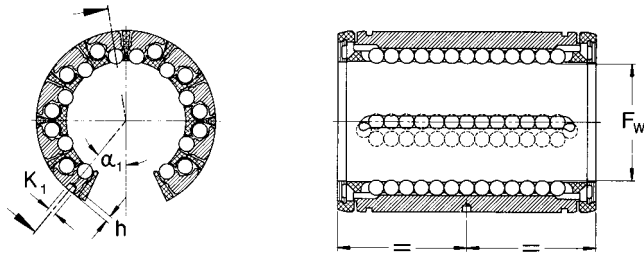

LBHT .. A Design

Dimensions					Appropriate grub screws	Dimensions					Appropriate grub screws
F_w	K_1	h	α_1		to DIN 417 or DIN 915	F_w	K	h	α_1		to DIN 417 or DIN 915
mm		mm	degrees	—		mm		mm	degrees	—	
20	$2,6 \pm 0,05$	$1,3 \pm 0,2$	47°		M 4	50	$4,1 \pm 0,05$	$1,8 \pm 0,3$	39°		M 6
25	$2,6 \pm 0,05$	$1,3 \pm 0,2$	55° 12'		M 4						
30	$3,6 \pm 0,05$	$1,4 \pm 0,2$	39° 15'		M 5						
40	$3,6 \pm 0,05$	$1,4 \pm 0,2$	38° 51'		M 5						

Grease nipples for LBC .. A linear ball bearings and LPA linear plain bearings

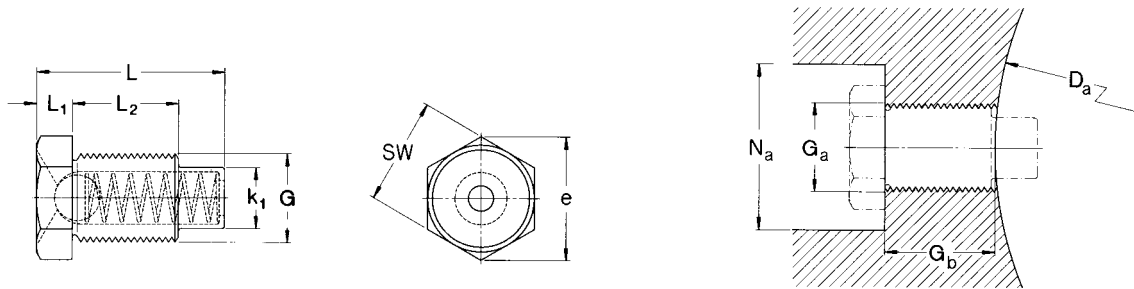

Dimensions									Designations	Attachment dimensions			
Bearing Grease nipple									Grease nipple	Housing			
F_w	G	L	L_1	L_2	k_1	e	SW		D_a	G_a	G_b $\pm 0,2$	N_a	
mm	—	mm						—	mm	—	mm		
12	M 4	7,7	1,5	3,5	3,0	5,5	5	VN-LHC 20	22	M 4	3,8	13	
16	M 4	7,7	1,5	3,5	3,0	5,5	5	VN-LHC 20	26	M 4	3,8	13	
20	M 4	7,7	1,5	3,5	3,0	5,5	5	VN-LHC 20	32	M 4	3,8	13	
25	M 5	11,1	2,0	5,0	3,5	6,6	6	VN-LHC 40	40	M 5	5,2	15	
30	M 5	11,1	2,0	5,0	3,5	6,6	6	VN-LHC 40	47	M 5	5,2	15	
40	M 5	11,1	2,0	5,0	3,5	6,6	6	VN-LHC 40	62	M 5	5,2	15	
50	M 6	14,8	2,5	7,0	4,5	7,8	7	VN-LHC 50	75	M 6	7,2	15	
60	M 8	20,5	3,5	10,5	6	11,1	10	VN-LHC 80	90	M 8	11,2	18	
80	M 8	20,5	3,5	10,5	6	11,1	10	VN-LHC 80	120	M 8	5,2	18	

LBCR .. A linear ball bearings

in closed design

F_w 5-80 mm

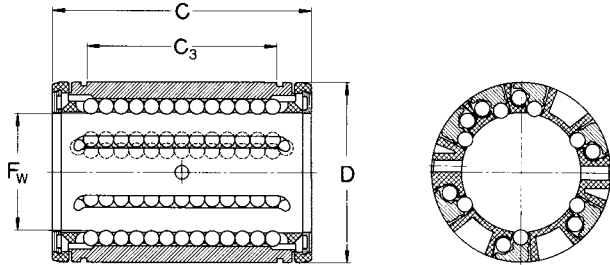

LBCR .. A linear ball bearing with 2 shields

LBCR .. A design

Dimensions				No. of ball rows	Basic load ratings		Mass	Designations	
F_w	D	C	C_3		dyn. C	stat. C_0		Linear ball bearing with 2 shields	2 double lip seals
mm				—	N		kg		
5	12	22	12	4	280	210	0,005	LBCR 5 A	LBCR 5 A-2LS
8	16	25	14	4	490	355	0,010	LBCR 8 A	LBCR 8 A-2LS
12	22	32	20	6	1 160	980	0,023	LBCR 12 A	LBCR 12 A-2LS
16	26	36	22	6	1 500	1 290	0,030	LBCR 16 A	LBCR 16 A-2LS
20	32	45	28	7	2 240	2 040	0,059	LBCR 20 A	LBCR 20 A-2LS
25	40	58	40	7	3 350	3 350	0,11	LBCR 25 A	LBCR 25 A-2LS
30	47	68	48	7	5 600	5 700	0,18	LBCR 30 A	LBCR 30 A-2LS
40	62	80	56	7	9 000	8 150	0,35	LBCR 40 A	LBCR 40 A-2LS
50	75	100	72	7	13 400	12 200	0,60	LBCR 50 A	LBCR 50 A-2LS
60	90	125	95	7	20 400	18 000	1,25	LBCR 60 A	LBCR 60 A-2LS
80	120	165	125	7	37 500	32 000	3,0	LBCR 80 A	LBCR 80 A-2LS

Upon request these bearings are available in stainless steel execution.

Designation: e.g. **LBCR 20 A-2LS/HV6**

Linear ball bearings with one seal are available on request.

Axial location with snap ring.

For axial location and protection against relative motion see pages 16/17.

Snap rings according to DIN 471.

LBCD .. A linear ball bearings

self aligning in closed design

F_w 12-50 mm

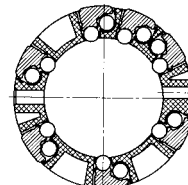
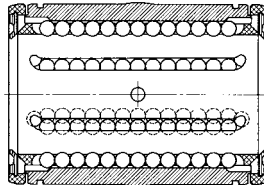
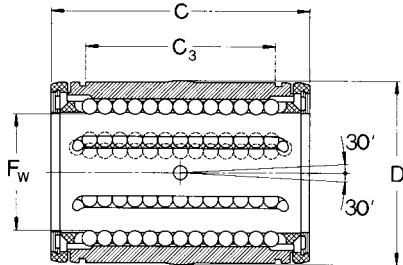

Linear ball bearing
with 2 shields

Linear ball bearing
with 2 seals

LBCD .. A design

Dimensions				No. of ball rows	Basic load ratings		Mass	Designations	
F_w	D	C	C_3		dyn. C	stat C_0		Linear ball bearings with 2 shields	2 double lip seals
mm				—	N		kg		
12	22	32	20	6	1 080	815	0,022	LBCD 12 A	LBCD 12 A-2LS
16	26	36	22	6	1 320	865	0,029	LBCD 16 A	LBCD 16 A-2LS
20	32	45	28	7	2 000	1 370	0,057	LBCD 20 A	LBCD 20 A-2LS
25	40	58	40	7	2 900	2 040	0,11	LBCD 25 A	LBCD 25 A-2LS
30	47	68	48	7	4 650	3 250	0,17	LBCD 30 A	LBCD 30 A-2LS
40	62	80	56	7	7 800	5 200	0,34	LBCD 40 A	LBCD 40 A-2LS
50	75	100	72	7	11 200	6 950	0,58	LBCD 50 A	LBCD 50 A-2LS

Upon request these bearings are available in stainless steel execution.

Designation: e.g. LBCD 20 A-2LS/HV6

Linear ball bearings with one seal are available on request.

For axial location and protection against relative motion see pages 16/17.
Snap rings according to DIN 471.

LBCT .. A/LBHT .. A linear ball bearings

in open design

F_w 12-80 mm

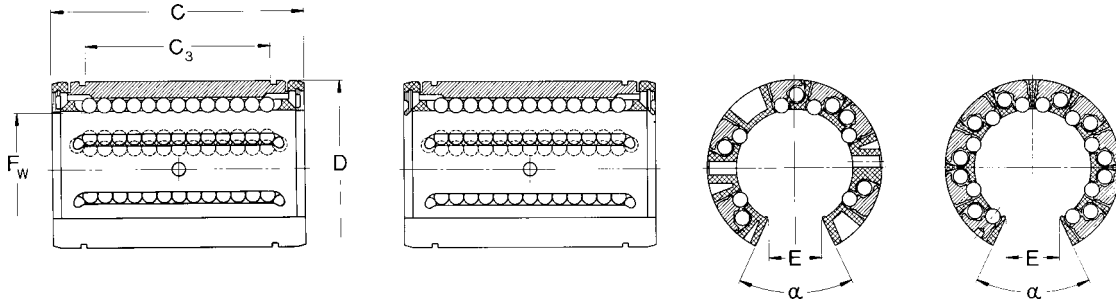

LBCT .. A linear ball bearing with 2 shields

LBCT .. A linear ball bearing with 2 seals

LBCT .. A design

LBHT .. A design

Dimensions					No. of ball rows	Basic load ratings		Mass	Designations		
F_w	D	C	C_3	$E^{1)}$		deg.	—		dyn. C	stat. C_0	kg
12	22	32	20	7,6	78	5	1 160	980	0,013	LBCT 12 A	LBCT 12 A-2LS
16	26	36	22	10,4	78	5	1 500	1 290	0,017	LBCT 16 A	LBCT 16 A-2LS
20	32	45	28	10,8	60	6	2 240	2 040	0,036	LBCT 20 A	LBCT 20 A-2LS
	32	45	28	10,8	60	8	2 650	2 650	0,043	LBHT 20 A	LBHT 20 A-2LS
25	40	58	40	13,2	60	6	3 350	3 350	0,071	LBCT 25 A	LBCT 25 A-2LS
	40	58	40	13,2	60	9	4 900	5 100	0,095	LBHT 25 A	LBHT 25 A-2LS
30	47	68	48	14,2	50	6	5 600	5 700	0,114	LBCT 30 A	LBCT 30 A-2LS
	47	68	48	14,2	50	10	7 200	8 000	0,160	LBHT 30 A	LBHT 30 A-2LS
40	62	80	56	18,7	50	6	9 000	8 150	0,23	LBCT 40 A	LBCT 40 A-2LS
	62	80	56	18,7	50	10	11 600	11 400	0,33	LBHT 40 A	LBHT 40 A-2LS
50	75	100	72	23,6	50	6	13 400	12 220	0,39	LBCT 50 A	LBCT 50 A-2LS
	75	100	72	23,6	50	10	17 300	17 000	0,56	LBHT 50 A	LBHT 50 A-2LS
60	90	125	95	29,6	54	6	20 400	18 000	0,72	LBCT 60 A	LBCT 60 A-2LS
80	120	165	125	38,4	54	6	37 500	32 000	1,67	LBCT 80 A	LBCT 80 A-2LS

Upon request these bearings are available in stainless steel execution.

Designation: e.g. LBCT/LBHT 20 A-2LS/HV6

Linear ball bearings with one seal are available on request.

¹⁾ Smallest sector width for diameter F_w . For axial location and protection against relative motion see pages 16/17.

LBCF .. A linear ball bearings

self-aligning in open design

F_w 12-50 mm

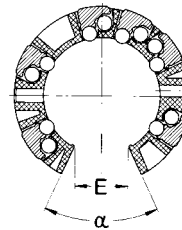
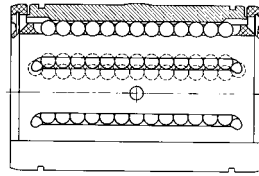
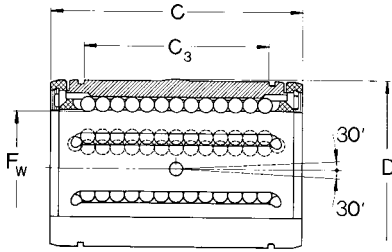

LBCF .. A linear ball bearing with 2 shields

LBCF .. A linear ball bearing with 2 seals

LBCF .. A design

Dimensions						No. of ball rows	Basic load ratings		Mass	Designations	
F_w	D	C	C_3	$E^{1)}$	α		dyn. C	stat. C_0		Linear ball bearing with 2 shields	2 double lip seals
mm					Deg.	—	N		kg		
12	22	32	20	7,6	78	5	1 080	815	0,012	LBCF 12 A	LBCF 12 A-2LS
16	26	36	22	10,4	78	5	1 320	865	0,016	LBCF 16 A	LBCF 16 A-2LS
20	32	45	28	10,8	60	6	2 000	1 370	0,035	LBCF 20 A	LBCF 20 A-2LS
25	40	58	40	13,2	60	6	2 900	2 040	0,070	LBCF 25 A	LBCF 25 A-2LS
30	47	68	48	14,2	50	6	4 650	3 250	0,11	LBCF 30 A	LBCF 30 A-2LS
40	62	80	56	18,7	50	6	7 800	5 200	0,22	LBCF 40 A	LBCF 40 A-2LS
50	75	100	72	23,6	50	6	11 200	6 950	0,37	LBCF 50 A	LBCF 50 A-2LS

Upon request these bearings are available in stainless steel execution.

Designation: e.g. LBCF 20 A-2LS/HV6

Linear ball bearings with one seal are available on request.

¹⁾ Smallest sector width for diameter F_w . For axial location and protection against relative motion see pages 16/17.

LPAR/LPAT linear plain bearings

closed and open design

F_w 5-50 mm

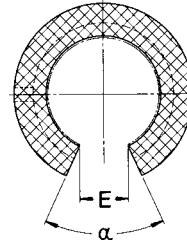
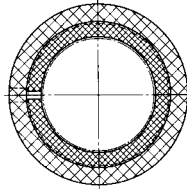
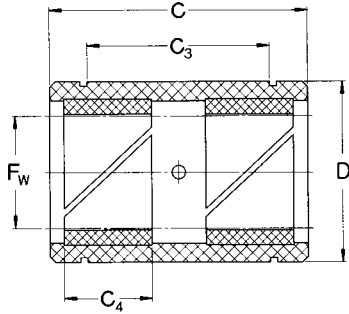

LPAR linear plain bearing

LPAR design

LPAT design

Dimensions							Basic load ratings			Mass		Designations	
F_w	D	C	C_3	C_4	$E^{1)}$	α	dyn. at 0,1 m/s C	4 m/s C	stat. C_0	Design closed	open	Linear plain bearing closed	open
mm	-0,05					Deg.	N			kg		—	
5	12	22	12	7	-	-	280	7	980	0,003	-	LPAR 5	-
8	16	25	14	8	-	-	510	13	1 800	0,005	-	LPAR 8	-
12	22	32	20	10	7,6	78	965	24	3 350	0,012	0,008	LPAR 12	LPAT 12
16	26	36	22	12	10,4	78	1 530	38	5 400	0,016	0,012	LPAR 16	LPAT 16
20	32	45	28	15	10,8	60	2 400	60	8 300	0,03	0,023	LPAR 20	LPAT 20
25	40	58	40	20	13,2	60	4 000	100	14 000	0,06	0,045	LPAR 25	LPAT 25
30	47	68	48	23	14,2	50	5 500	137	19 300	0,09	0,07	LPAR 30	LPAT 30
40	62	80	56	25	18,7	50	8 000	200	28 000	0,20	0,15	LPAR 40	LPAT 40
50	75	100	72	30	23,6	50	12 000	300	41 500	0,34	0,26	LPAR 50	LPAT 50
60	90	125	95	35	29,6	54	16 600	415	60 000	0,63	0,46	LPAR 60	LPAT 60
80	120	165	125	45	38,4	54	29 000	720	100 000	1,50	1,10	LPAR 80	LPAT 80

¹⁾ Smallest sector width for diameter F_w .

For axial location and protection against relative motion see pages 16/17. Snap rings according to DIN 471.

Linear Bearing units with LBC .. A linear ball bearings or LPA linear plain bearings

A comprehensive range of linear bearing units is available, based on linear ball bearings and linear plain bearings. In addition to the basic design with one bearing, flanged units can also be supplied as well as tandem and quadro units.

LUC linear bearing units

Units of the LUC series have cast aluminium housings. Optimised design with a minimum of material results in low weight of the product while maintaining high strength and stiffness. Acceleration and inertial forces are thus kept to a minimum. LUC linear bearing units are available for shaft diameters from 8 to 80 mm. The various designs are described below in greater detail.

LUCD/LUCR linear bearing units

SKF linear bearing units of the LUCD/LUCR series offer a simple means of achieving economical shaft guides. The units comprise a closed housing, a linear ball bearing of series LBCD .. A or LBCR .. A and are supplied as standard with shields. LUCD .. A linear bearing units (for shaft diameters from 12 to 80 mm) are normally supplied with self-aligning LBCD .. A linear ball bearings.



Linear bearing unit LUND

Linear bearing unit LUCE

Linear bearing unit LUCF

Linear bearing unit LQCD

Linear bearing unit LTCF

LUCR linear bearing units (for shaft diameters from 12 to 80 mm) are supplied with rigid LBCR .. A linear ball bearings. A grease nipple serves to retain the bearing axially and prevent it from turning. The bearings are thus readily relubricated. On request, these units are also available fitted with LPAR linear plain bearings (designation LUCR..PA). Units fitted with LBAR linear bearings (for shaft diameters 8 mm) can not be relubricated . The bearings are axially located in the housing bores by means of two retaining rings. The designation of these units is: LUCR/LUCR .. PA.

LUCE/LUCS linear bearing units

LUCE/LUCS linear bearing units are similar in design to the LUCD/LUCR units but instead of a closed housing they have a slotted housing with adjustment screw. They can be used for arrangements requiring zero clearance or preload. LUCE/LUCD linear ball bearing units are supplied with selfaligning LBCD .. A linear ball bearings. LUCS/LUCR linear ball bearing units are supplied with rigid LBCR .. A linear ball bearing units. These units are not available with linear plain bearings.

LUCF/LUCT linear bearing units

LUCF/LUCT linear bearing units are designed for applications where, because of heavy loads and/or long guidance lengths, the shaft must be supported either partially or along its entire length. For this reason the housings as well as the bearings have one sector cut away. In all other respects they are similar in design to the closed LUCD/LUCR units. These open linear bearing units are available as standard with the self-aligning linear ball bearing LBCF .. A or the rigid linear ball bearing LBCT .. A. For the above-mentioned sizes, axial location is achieved by means of a grease nipple, consequently they may be relubricated. Where high load carrying capacity or long operating life is required, LUCT units can also be supplied fitted with

LBHT .. A linear ball bearings in sizes 20 to 50 which have a particularly high load rating (Designation: LUCT..BH). These units may also be relubricated. Bearing units may also be supplied fitted with linear plain bearings (Designation LUCT..PA).

LUN linear bearing units

LUN linear bearing units are supplied as standard with shielded or sealed self-aligning linear ball bearings. Three versions are available: closed (LUND), adjustable (LUNE) and open, adjustable (LUNF). They are suitable for shaft diameters from 12 to 50 mm. In contrast to the LUC linear bearing unit described above, the housings consist of an extruded aluminium profile enveloping the linear ball bearing along its whole length. Two diagonally opposed attachment holes are provided. By using through bolts, direct fixing into the threaded holes on the underside can be employed. All units may be relubricated.

LVCD/LVCR flanged linear bearing units

LVCD and LVCR flanged linear bearing units consist of a closed flanged housing made of cast iron and fitted with a self-aligning LBCD .. A linear ball bearing (d = 12 to 50 mm) respectively a rigid LBCR .. A linear ball bearing (d = 12 to 80 mm). The bearings, sealed at both sides, are located axially by means of pins. The flange is machined on both faces thus allowing mounting on the front or rear of the machine sides. Flanged linear bearing units are not designed for relubrication and must therefore be filled with the appropriate amount of lubricant before mounting.

LQCD with closed housing and LQCF with open housing. Using quadro units, used in combination with LEAS tandem shaft blocks (closed design) or LRCB shaft supports (open design) it is possible to produce simple linear slides and tables. Details of tables are given on pages 43 to 45 of this catalogue. The LQC design is available for shaft sizes from 8 to 50 mm. An exception is the size 8 unit which is fitted with LBCR 8 A-LS non self-aligning linear ball bearings (full designation LQCR 8 BA-2LS). LQCF units are suitable for shaft diameters from 12 to 50 mm. All quadro units may be attached to their supporting surfaces either by head cap screws inserted from below or via the threaded holes in the housing.

LTC tandem linear bearing units

SKF tandem linear bearing units consist of a solid extruded aluminium housing and two self-aligning linear ball bearings mounted one behind the other. A grease nipple is used to secure each bearing in position and prevent it from turning. Tandem linear bearing units enable the construction of linear guidance systems such as tables of any required width. The housing may be attached to its supporting surface from below using head cap screws or from above via the two threaded holes in the housing. These tandem units are available in two versions : closed (LTCD) or open (LTCF). These bearing units are supplied with seals as standard. The linear ball bearings are supplied with one seal as standard. Shaft diameter sizes range from 12 to 50 mm.

LQC quadro linear bearing units

SKF quadro linear bearing units consist of a one-piece aluminium housing with two bores arranged in parallel, each with two self-aligning linear ball bearings. The bearings are sealed on the external ends only. The bearings are retained in position axially and also prevented from turning. Except for units of size 8, relubrication is possible . SKF quadro units are available in two designs:

Note
All linear ball bearing units F_w 12-50 mm can be fitted with non self aligning linear ball bearings on request.

LUCD linear bearing units

with LBCD .. A linear ball bearing and closed housing, self-aligning, can be relubricated

LUCR linear bearing units

with LBCR .. A linear ball bearing and closed housing, can be relubricated

F_w 8-80 mm

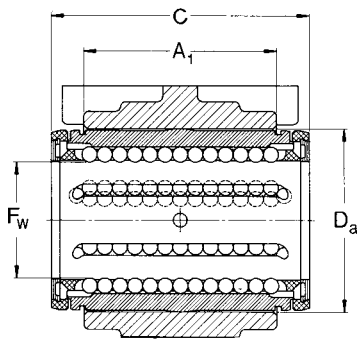

Linear bearing unit with 2 shields

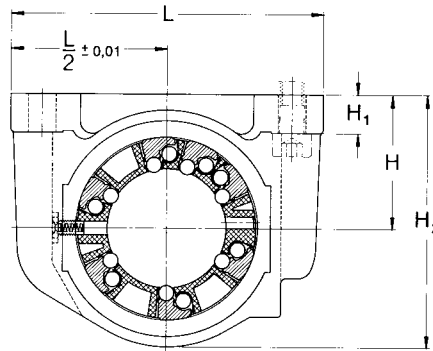

LUCD design

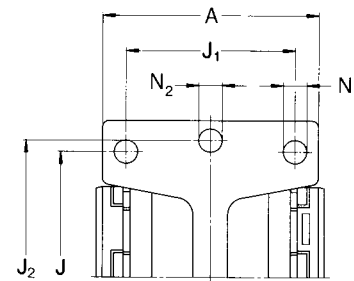

Dimensions

F_w A A₁ C D_a H H₁ H₂ J J₁ J₂ L N²⁾ N₂²⁾

±0,01

Basic load ratings

dyn. C stat. C₀

Mass Designations

Linear ball bearing unit with 2 shields 2 double lip seals

mm														N	kg	—		
8	27	14	25	16	15	5,5	28	25	20	35	45	3,2	5,3	490	355	0,029	LUCR 8 ¹⁾	LUCR 8-2LS ¹⁾
12	31	20	32	22	18	6	34,5	32	23	42	52	4,3	5,3	1 080	815	0,060	LUCD 12	LUCD 12-2LS
16	34,5	22	36	26	22	7	40,5	40	26	46	56	4,3	5,3	1 320	865	0,078	LUCD 16	LUCD 16-2LS
20	41	28	45	32	25	8	48	45	32	58	70	4,3	6,4	2 000	1 370	0,16	LUCD 20	LUCD 20-2LS
25	52	40	58	40	30	10	58	60	40	68	80	5,3	6,4	2 900	2 040	0,31	LUCD 25	LUCD 25-2LS
30	59	48	68	47	35	10	67	68	45	76	88	6,4	6,4	4 650	3 250	0,45	LUCD 30	LUCD 30-2LS
40	74	56	80	62	45	12	85	86	58	94	108	8,4	8,4	7 800	5 200	0,81	LUCD 40	LUCD 40-2LS
50	66	72	100	75	50	14	99	108	50	116	135	8,4	10,5	11 200	6 950	1,33	LUCD 50	LUCD 50-2LS
60	84	95	125	90	60	18	118	132	65	138	160	10,5	13	20 400	18 000	2,60	LUCR 60	LUCR 60-2LS
80	113	125	165	120	80	22	158	170	90	180	205	13	13	37 500	32 000	6,25	LUCR 80	LUCR 80-2LS

LUCD/LUCR bearing units are available on request in stainless steel execution.

Designation: e.g. LUCD/LUCR 20-2LS/HV6

LUCD linear ball bearing units can also be fitted with rigid linear ball bearings of type LBCR. Designation: e.g. LUCR 12-2LS.

LUCR/LUCD linear bearing units F_w 8-80 are also available fitted with linear plain bearings. Designation: e.g. LUCR 20 PA.

For suitable shaft blocks LSCS/LSNS for these bearing units, see pages 39 and 40 of this catalogue.

¹⁾ Linear ball bearings fitted to these units are secured with snap rings according to DIN 471, cannot be relubricated, not self-aligning.

²⁾ For screws with internal hexagon to DIN 912 / ISO 4762

LUCE linear bearing units

with LBCD .. A linear ball bearing and slotted housing, self-aligning, can be relubricated, adjustable in radial direction

LUCS linear bearing units

with LBCR .. A linear ball bearing and slotted housing, can be relubricated, adjustable in radial direction

F_w 8-80 mm

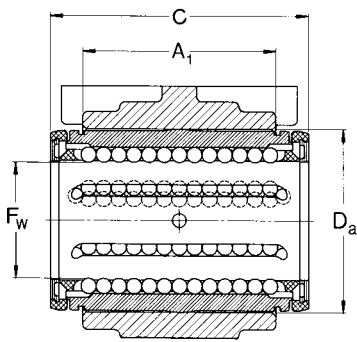

Linear bearing unit with 2 shields

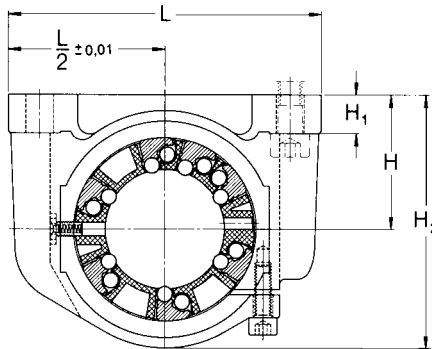

LUCE design

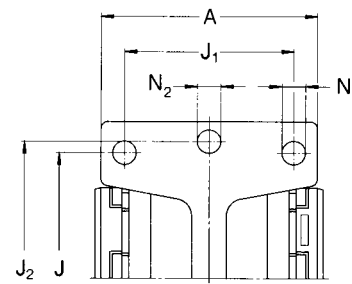

Dimensions													Basic load ratings		Mass	Designations		
F _w	A	A ₁	C	D _a	H	H ₁	H ₂	J	J ₁	J ₂	L	N ²⁾	N ₂ ²⁾	dyn. C	stat. C ₀	kg	Linear bearing unit with 2 shields	2 double lip seals
mm													N	kg	—			
8	27	14	25	16	15	5,5	28	25	20	35	45	3,2	5,3	490	355	0,029	LUCS 8 ¹⁾	LUCS 8-2LS ¹⁾
12	31	20	32	22	18	6	34,5	32	23	42	52	4,3	5,3	1 080	815	0,060	LUCE 12	LUCE 12-2LS
16	34,5	22	36	26	22	7	40,5	40	26	46	56	4,3	5,3	1 320	865	0,078	LUCE 16	LUCE 16-2LS
20	41	28	45	32	25	8	48	45	32	58	70	4,3	6,4	2 000	1 370	0,16	LUCE 20	LUCE 20-2LS
25	52	40	58	40	30	10	58	60	40	68	80	5,3	6,4	2 900	2 040	0,31	LUCE 25	LUCE 25-2LS
30	59	48	68	47	35	10	67	68	45	76	88	6,4	6,4	4 650	3 250	0,45	LUCE 30	LUCE 30-2LS
40	74	56	80	62	45	12	85	86	58	94	108	8,4	8,4	7 800	5 200	0,81	LUCE 40	LUCE 40-2LS
50	66	72	100	75	50	14	99	108	50	116	135	8,4	10,5	11 200	6 950	1,33	LUCE 50	LUCE 50-2LS
60	84	95	125	90	60	18	118	132	65	138	160	10,5	13	20 400	18 000	2,60	LUCS 60	LUCS 60-2LS
80	113	125	165	120	80	22	158	170	90	180	205	13	13	37 500	32 000	6,25	LUCS 80	LUCS 80-2LS

Upon request LUCE/LUCS bearing units are available in stainless steel execution.

Designation: e.g. LUCE/LUCS 20-2LS/HV6

LUCE linear bearing units can also be fitted with rigid linear ball bearings of type LBCR .. A. Designation: e.g. LUCS 20-2LS.

For suitable shaft blocks LSCS/LSNS for these bearing units, see pages 39 and 40 of this catalogue.

¹⁾ Linear ball bearings fitted to these units are secured with snap rings according to DIN 471, cannot be relubricated, not self-aligning.

²⁾ For screws with internal hexagon to DIN 912 / ISO 4762.

LUCF linear bearing units

with LBCF .. A linear ball bearing and open housing, self-aligning, clearance adjustable, can be relubricated

LUCT linear bearing units

with LBCT .. A linear ball bearings and open housing, clearance adjustable, can be relubricated

F_w 12-80 mm

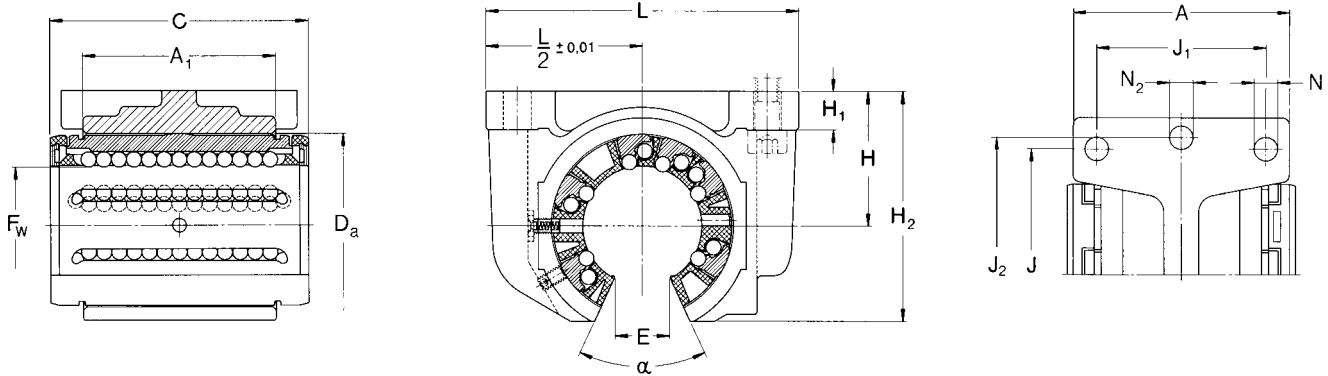

Linear bearing unit with 2 shields

LUCF design

Dimensions																Basic load ratings		Mass	Designations	
F _w	A	A ₁	C	D _a	H	H ₁	H ₂	J	J ₁	J ₂	L	N ²⁾	N ₂ ²⁾	E ¹⁾	α	dyn. C	stat. C ₀	kg	Linear bearing unit with 2 shields	2 double lip seals
mm																Deg. N	kg	—		
12	31	20	32	22	18	6	28	32	23	42	52	4,3	5,3	7,6	78	1 080	815	0,052	LUCF 12	LUCF 12-2LS
16	34,5	22	36	26	22	7	35	40	26	46	56	4,3	5,3	10,4	78	1 320	865	0,069	LUCF 16	LUCF 16-2LS
20	41	28	45	32	25	8	42	45	32	58	70	4,3	6,4	10,8	60	2 000	1 370	0,14	LUCF 20	LUCF 20-2LS
25	52	40	58	40	30	10	51	60	40	68	80	5,3	6,4	13,2	60	2 900	2 040	0,28	LUCF 25	LUCF 25-2LS
30	59	48	68	47	35	10	60	68	45	76	88	6,4	6,4	14,2	50	4 650	3 250	0,41	LUCF 30	LUCF 30-2LS
40	74	56	80	62	45	12	77	86	58	94	108	8,4	8,4	18,7	50	7 800	5 200	0,71	LUCF 40	LUCF 40-2LS
50	66	72	100	75	50	14	88	108	50	116	135	8,4	10,5	23,6	50	11 200	6 950	1,17	LUCF 50	LUCF 50-2LS
60	84	95	125	90	60	18	105	132	65	138	160	10,5	13,0	29,6	54	20 400	18 000	2,6	LUCT 60	LUCT 60-2LS
80	113	125	165	120	80	22	140	170	90	180	205	13,0	13,0	38,4	54	37 500	32 000	6,25	LUCT 80	LUCT 80-2LS

Upon request LUCF/LUCT bearing units are available in stainless steel execution.

Designation: e.g. LUCF/LUCT 20-2LS/HV6

LUCF linear ball bearing units can also be fitted with rigid linear ball bearings of type LBCT .. A.

Designation: e.g. LUCT 20-2LS.

LUCF/LUCT linear bearing units F_w 12-80 are also available fitted with linear plain bearings.

Designation: e.g. LUCT 20 PA.

For suitable shaft supports for these bearing units, designation LRCB..., see page 42 of this catalogue.

¹⁾ Minimum sector width at diameter F_w.

²⁾ For cylindrical screws with internal hexagon to DIN 912 / ISO 4762.

LUCT ... BH linear bearing units

with LBHT .. A linear ball bearing and open housing, clearance adjustable, can be relubricated

F_w 20-50 mm

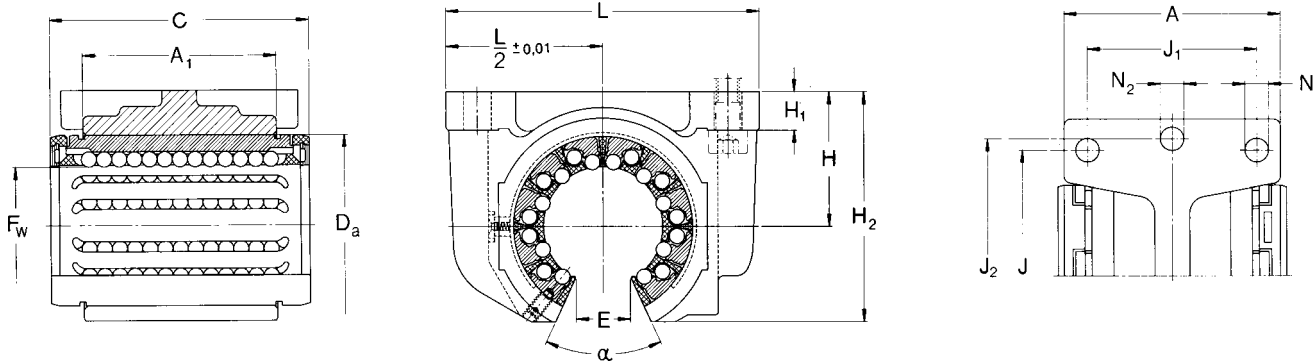

Linear bearing unit
with 2 shields

LUCT . . BH design

Dimensions																Basic load ratings		Mass		Designations	
F_w	A	A_1	C	D_a	H	H_1	H_2	J	J_1	J_2	L	$N^{2)}$	$N_2^{2)}$	$E^{1)}$	α	dyn. C	stat. C_0	kg	—	Linear bearings unit with 2 shields	2 double lip seals
mm					$\pm 0,01$										Deg.	N					
20	41	28	45	32	25	8	42	45	32	58	70	4,3	6,4	10,8	60	2 650	2 650	0,16	—	LUCT 20 BH	LUCT 20 BH-2LS
25	52	40	58	40	30	10	51	60	40	68	80	5,3	6,4	13,2	60	4 900	5 100	0,32	—	LUCT 25 BH	LUCT 25 BH-2LS
30	59	48	68	47	35	10	60	68	45	76	88	6,4	6,4	14,2	50	7 200	8 000	0,48	—	LUCT 30 BH	LUCT 30 BH-2LS
40	74	56	80	62	45	12	77	86	58	94	108	8,4	8,4	18,7	50	11 600	11 400	0,86	—	LUCT 40 BH	LUCT 40 BH-2LS
50	66	72	100	75	50	14	88	108	50	116	135	8,4	10,5	23,6	50	17 300	17 000	1,44	—	LUCT 50 BH	LUCT 50 BH-2LS

Upon request LUCT bearing units are available in stainless steel execution.

Designation: e.g. LUCT 20-2LS/HV6

Suitable shaft supports, designation LRCB, are available for these units. See page 42 for details.

¹⁾ Smallest sector width at diameter F_w .

²⁾ For screws with internal hexagon to DIN 912 / ISO 4762.

LUND linear bearing units

with LBCD .. A linear ball bearings and closed housing, self-aligning, can be relubricated

F_w 12-50 mm

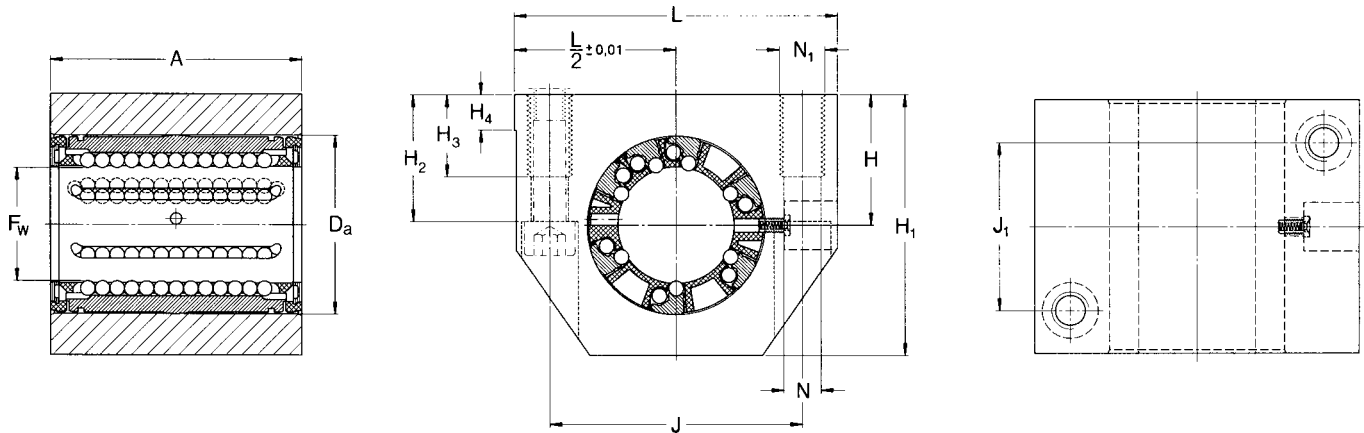

Linear bearing unit
with 2 shields

LUND design

Dimensions													Basic load ratings		Mass	Designations	
F_w	A	D_a	H	H_1	H_2	H_3	H_4	J	J_1	L	$N^{1)}$	$N_1^{1)}$	dyn. C	stat. C_0	kg	Linear bearing unit with 2 shields	2 double lip seals
mm			$\pm 0,01$										N			—	—
12	32	22	18	35	16,5	11	6	32	23	43	4,3	M 5	1 080	815	0,10	LUND 12	LUND 12-2LS
16	37	26	22	42	21	13	7	40	26	53	5,3	M 6	1 320	865	0,17	LUND 16	LUND 16-2LS
20	45	32	25	50	24	18	7,5	45	32	60	6,6	M 8	2 000	1 370	0,27	LUND 20	LUND 20-2LS
25	58	40	30	61	29	22	8,5	60	40	78	8,4	M 10	2 900	2 040	0,56	LUND 25	LUND 25-2LS
30	68	47	35	70	34	22	9,5	68	45	87	8,4	M 10	4 650	3 250	0,83	LUND 30	LUND 30-2LS
40	80	62	45	90	44	26	11	86	58	108	10,5	M 12	7 800	5 200	1,52	LUND 40	LUND 40-2LS
50	100	75	50	105	49	35	11	108	50	132	13,5	M 16	11 200	6 950	2,61	LUND 50	LUND 50-2LS

Upon request LUND bearing units are available in stainless steel execution.

Designation: e.g. LUND 20-2LS/HV6

For suitable shaft blocks LSCS/LSNS for these bearing units, see pages 39 and 40 of this catalogue.

¹⁾ For screws with internal hexagon to DIN 912 / ISO 4762.

LUNE linear bearing units

with LBCD .. A linear ball bearings and slotted housing, self-aligning, clearance adjustable, can be relubricated
 F_w 12-50 mm

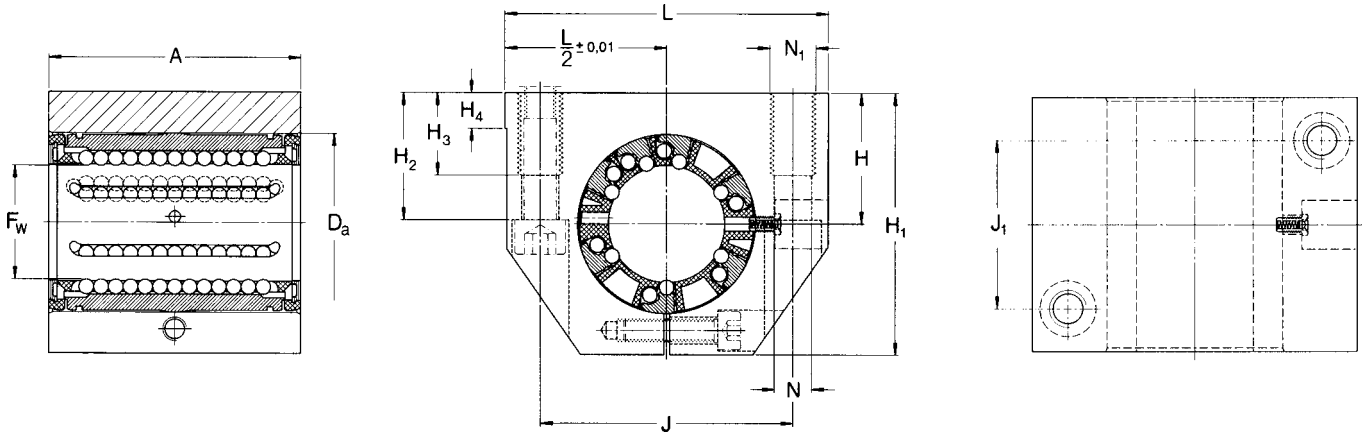

Linear bearing unit
with 2 shields

LUNE design

Dimensions													Basic load ratings		Mass	Designations	
F_w	A	D_a	H	H_1	H_2	H_3	H_4	J	J_1	L	$N^{1)}$	$N_1^{1)}$	dyn. C	stat. C_0	kg	Linear bearing unit with 2 shields	2 double lip seals
mm													—	N	—	—	
12	32	22	18	35	16,5	11	6	32	23	43	4,3	M 5	1 080	815	0,10	LUNE 12	LUNE 12-2LS
16	37	26	22	42	21	13	7	40	26	53	5,3	M 6	1 320	865	0,17	LUNE 16	LUNE 16-2LS
20	45	32	25	50	24	18	7,5	45	32	60	6,6	M 8	2 000	1 370	0,27	LUNE 20	LUNE 20-2LS
25	58	40	30	61	29	22	8,5	60	40	78	8,4	M 10	2 900	2 040	0,56	LUNE 25	LUNE 25-2LS
30	68	47	35	70	34	22	9,5	68	45	87	8,4	M 10	4 650	3 250	0,83	LUNE 30	LUNE 30-2LS
40	80	62	45	90	44	26	11	86	58	108	10,5	M 12	7 800	5 200	1,52	LUNE 40	LUNE 40-2LS
50	100	75	50	105	49	35	11	108	50	132	13,5	M 16	11 200	6 950	2,61	LUNE 50	LUNE 50-2LS

Upon request LUNE bearing units are available in stainless steel execution.

Designation: e.g. LUNE 20-2LS/HV6

For suitable shaft blocks LSCS/LSNS for these bearing units, see pages 39 and 40 of this catalogue.

¹⁾ For screws with internal hexagon to DIN 912 / ISO 4762.

LUNF linear bearing units

with LBCF .. A linear ball bearings and open housing, self-aligning, clearance adjustable, can be relubricated
 F_w 12-50 mm

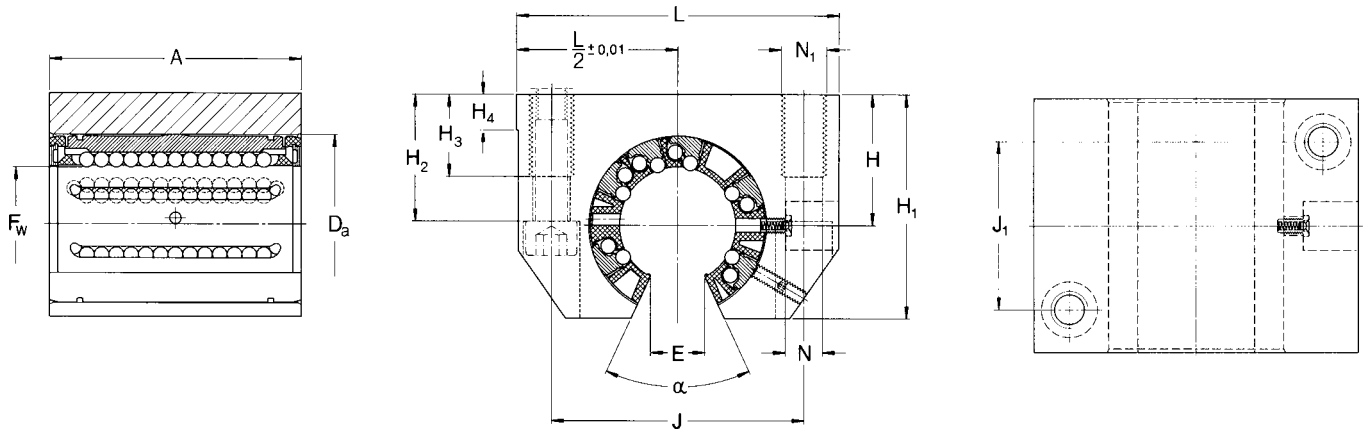

Linear bearing unit
with 2 shields

LUNF design

Dimensions																Basic load ratings		Mass	Designations	
F_w	A	D_a	H	H_1	H_2	H_3	H_4	J	J_1	L	$N^{2)}$	$N_1^{2)}$	$E^{1)}$	α	dyn. C	stat. C_0	kg	Linear bearing unit with 2 shields	2 double lip seals	
mm	mm	mm	mm	mm	mm	mm	mm	mm	mm	mm	mm	mm	mm	Deg.	N	N	kg	—	—	
12	32	22	18	28	16,5	11	6	32	23	43	4,3	M 5	7,6	78	1 160	980	0,08	LUNF 12	LUNF 12-2LS	
16	37	26	22	35	21	13	7	40	26	53	5,3	M 6	10,4	78	1 500	1 290	0,14	LUNF 16	LUNF 16-2LS	
20	45	32	25	42	24	18	7,5	45	32	60	6,6	M 8	10,8	60	2 240	2 040	0,23	LUNF 20	LUNF 20-2LS	
25	58	40	30	51	29	22	8,5	60	40	78	8,4	M 10	13,2	60	3 350	3 350	0,47	LUNF 25	LUNF 25-2LS	
30	68	47	35	60	34	22	9,5	68	45	87	8,4	M 10	14,2	50	5 600	5 700	0,71	LUNF 30	LUNF 30-2LS	
40	80	62	45	77	44	26	11	86	58	108	10,5	M 12	18,7	50	9 000	8 150	1,29	LUNF 40	LUNF 40-2LS	
50	100	75	50	88	49	35	11	108	50	132	13,5	M 16	23,6	50	13 400	12 200	2,16	LUNF 50	LUNF 50-2LS	

Upon request LUNF bearing units are available in stainless steel execution.

Designation: e.g. LUNF 20-2LS/HV6

Suitable shaft supports, designation LRCB.. are available for these units. See page 42 for details.

¹⁾ Smallest sector width at diameter F_w .

²⁾ For screws with internal hexagon to DIN 912 / ISO 4762.

LVCR flanged linear bearing units

with LBCR .. A linear ball bearings

F_w 12-80 mm

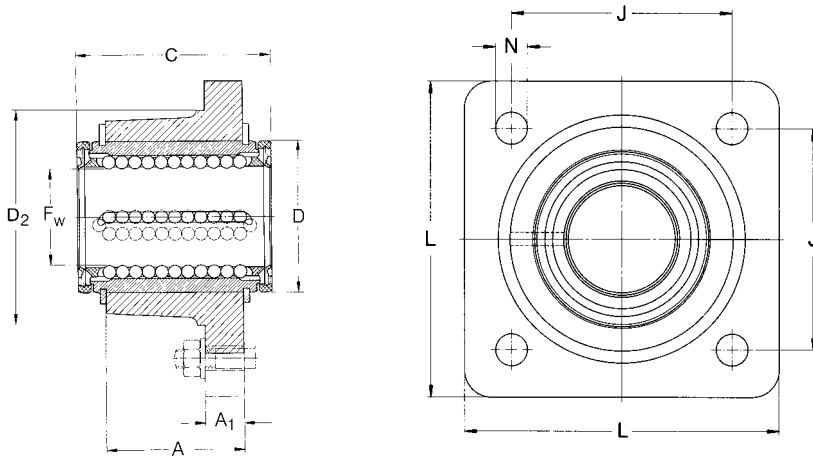

Linear bearing unit
with 2 seals

LVCR design

Dimensions				Basic load ratings		Mass	Designations					
F _w	A	A ₁	C	D	D ₂	J		L	N ¹⁾	dyn. C	stat. C ₀	kg
mm									N		kg	—
12	20	8	32	22	32	30	42	5,5	1 160	980	0,12	LVCR 12-2LS
16	22	8	36	26	38	35	50	5,5	1 500	1 290	0,17	LVCR 16-2LS
20	28	10	45	32	46	42	60	6,6	2 240	2 040	0,33	LVCR 20-2LS
25	40	12	58	40	58	54	74	6,6	3 350	3 350	0,68	LVCR 25-2LS
30	48	14	68	47	66	60	84	9	5 600	5 700	1,03	LVCR 30-2LS
40	56	16	80	62	90	78	108	11	9 000	8 150	2,00	LVCR 40-2LS
50	72	18	100	75	110	98	130	11	13 400	12 200	3,41	LVCR 50-2LS
60	95	22	125	90	135	120	160	13,5	20 400	18 000	6,35	LVCR 60-2LS
80	125	25	165	120	180	155	200	13,5	37 500	32 000	14,40	LVCR 80-2LS

Upon request LVCR bearing units are available in stainless steel execution.

Designation: e.g. LVCR 20-2LS/HV6

LVCR linear ball bearing units of sizes F_w 12-50 can also be fitted with linear bearings which are self-aligning
Designation: e.g. LVCD 12-2LS.

¹⁾ For screws with internal hexagon to DIN 912 / ISO 4762.

²⁾ Linear ball bearings fitted to these units are secured using pins.. to DIN 1470 or, in the case of Types 60 and 80, using retaining rings to DIN 471. They are not designed for relubrication.

LTCD tandem linear bearing units

with LBCD .. A self-aligning linear ball bearings and closed housing, can be relubricated
 F_w 12-50 mm

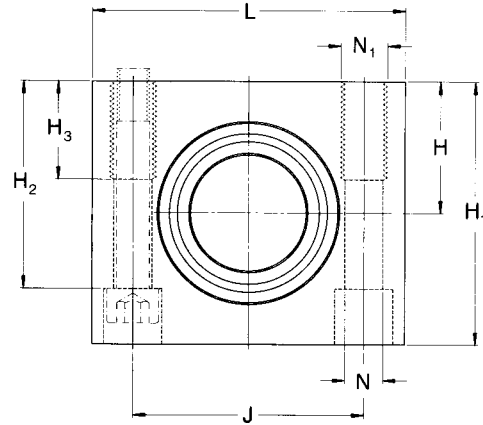
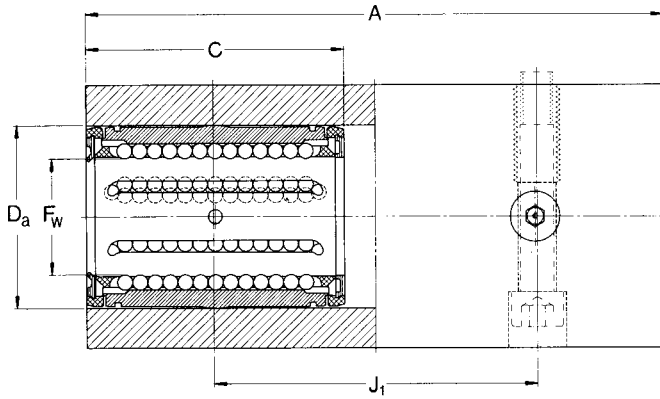

Linear bearing unit with shields (Fig. 1)²⁾

LTCD .. 2LS design

Dimensions														Basic load ratings		Ge-wicht	Designations Linear bearing unit with double lip seals
F_w	A	C	D_a	H <small>±0,01</small>	H_1	H_2	H_3	J	J_1	L	$N^{1)}$	$N_1^{1)}$	dyn. C	stat. C_0			
mm												—	N		kg	—	
12	76	32	22	18	35	27	13	30	40	42	5,3	M 6	1 760	1 630	0,25	LTCD 12-2LS	
16	84	36	26	22	41,5	33	13	36	45	50	5,3	M 6	2 160	1 730	0,39	LTCD 16-2LS	
20	104	45	32	25	49,5	39,5	18	45	55	60	6,4	M 8	3 200	2 750	0,70	LTCD 20-2LS	
25	130	58	40	30	59,5	47	22	54	70	74	8,4	M 10	4 750	4 150	1,29	LTCD 25-2LS	
30	152	68	47	35	69,5	55	26	62	85	84	10,5	M 12	7 500	6 550	1,95	LTCD 30-2LS	
40	176	80	62	45	89,5	71	34	80	100	108	13	M 16	12 700	10 400	3,71	LTCD 40-2LS	
50	224	100	75	50	99,5	81	34	100	125	130	13	M 16	18 300	14 000	6,20	LTCD 50-2LS	

Upon request LTCD bearing units are available in stainless steel execution.
 Designation: e.g. LTCD 20-2LS/HV6

For suitable shaft blocks LSCS/LSNS for these bearing units, see pages 39 and 40 of this catalogue.

¹⁾ For 2 screws with internal hexagon to DIN 912 / ISO 4762.

²⁾ Bore position as in top view, fig. 1:

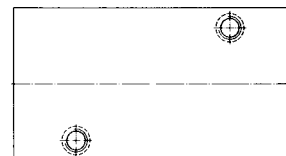

LTCF tandem linear bearing units

with LBCF .. A self-aligning linear ball bearings and open housing, can be relubricated.

F_w 12-50 mm

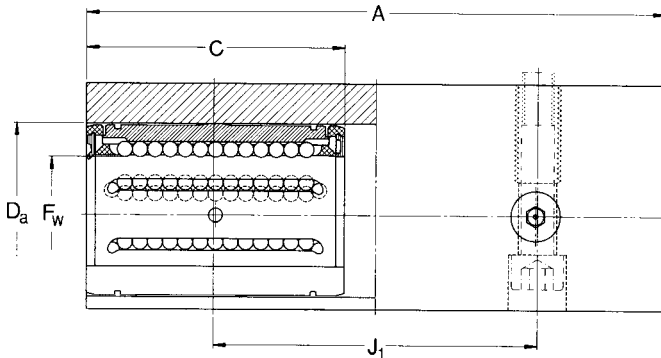

Linear bearing unit with shields (Fig 1)³⁾

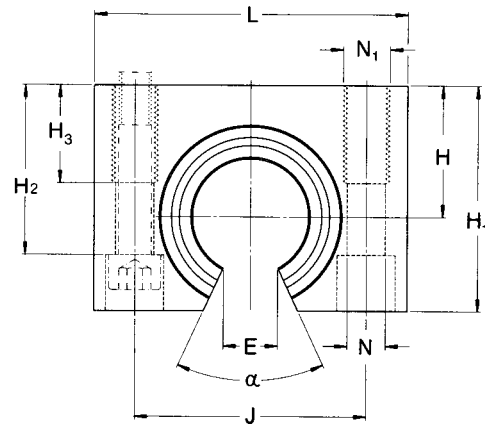

LTCF..2LS design

Dimensions															Basic load ratings		Mass	Designations
F_w	A	C	D_a	H	H_1	H_2	H_3	J	J_1	L	$N^2)$	$N_1^2)$	$E^1)$	α	dyn. C	stat. C_0	kg	Linear bearing unit with double lip seals
mm	mm	mm	mm	mm	mm	mm	mm	mm	mm	mm	mm	mm	mm	Deg.	N	N	kg	—
12	76	32	22	18	29	23,5	13	30	40	42	5,3	M 6	7,6	78	1 760	1 630	0,19	LTCF 12-2LS
16	84	36	26	22	35	28	13	36	45	50	5,3	M 6	10,4	78	2 160	1 730	0,30	LTCF 16-2LS
20	104	45	32	25	42	33,5	18	45	55	60	6,4	M 8	10,8	60	3 200	2 750	0,65	LTCF 20-2LS
25	130	58	40	30	51	40	22	54	70	74	8,4	M 10	13,2	60	4 750	4 150	1,02	LTCF 25-2LS
30	152	68	47	35	60	46,5	26	62	85	84	10,5	M 12	14,2	50	7 500	6 550	1,57	LTCF 30-2LS
40	176	80	62	45	77	61	34	80	100	108	13	M 16	18,7	50	12 700	10 400	2,97	LTCF 40-2LS
50	224	100	75	50	88	72	34	100	125	130	13	M 16	23,6	50	18 300	14 000	5,11	LTCF 50-2LS

Upon request LTCF bearing units are available in stainless steel execution.

Designation: e.g. LTCF 20-2LS/HV6

For suitable shaft supports for these bearing units, designation LRCB., see page 42 of this catalogue.

¹⁾ Smallest sector width at diameter F_w .

²⁾ For 2 screws with internal hexagon to DIN 912 / ISO 4762.

³⁾ Bore position as in top view, fig. 1:

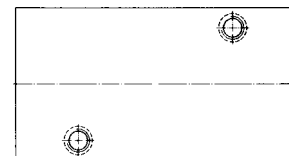

LQCR/LQCD quadro linear bearing units

with LBCD .. A self-aligning linear ball bearings and closed housing, can be relubricated.

F_w 8-50 mm

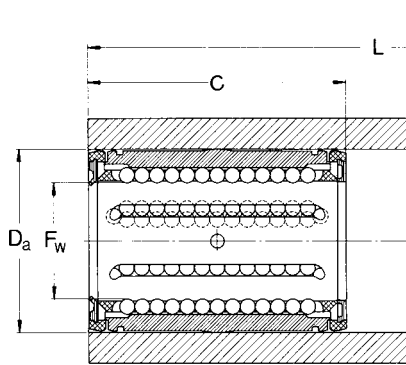

Linear bearing unit with seals

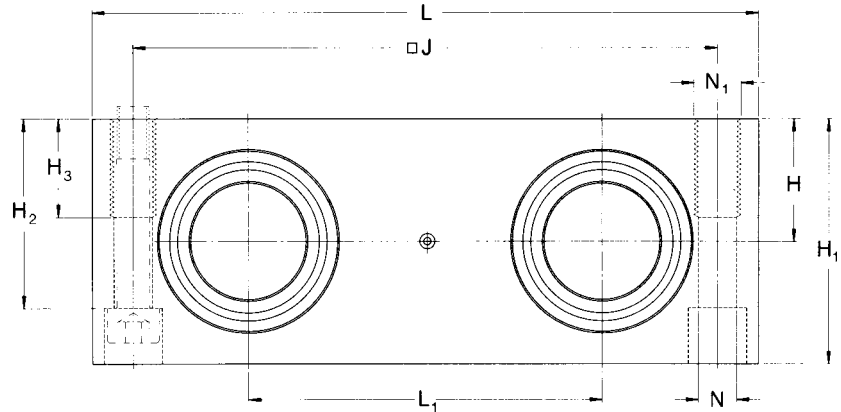

LQCD..2LS design

Dimensions											Basic load ratings		Mass	Designations	
F_w	C	D_a	H	H_1	H_2	H_3	J	L	L_1	$N^{2)}$	$N_1^{2)}$	dyn. C	stat. C_0	kg	Linear bearing unit with double lip seals
mm			$\pm 0,01$									N			—
8	25	16	11,5	23	17,5	11	55	65	32	4,3	M 5	1 290	1 420	0,23	LQCR 8-2LS ¹⁾
12	32	22	16	32	25	13	73	85	42	5,3	M 6	2 850	3 250	0,52	LQCD 12-2LS
16	36	26	18	36	29	13	88	100	54	5,3	M 6	3 450	3 450	0,78	LQCD 16-2LS
20	45	32	23	46	37,5	18	115	130	72	6,6	M 8	5 200	5 500	1,74	LQCD 20-2LS
25	58	40	28	56	45	22	140	160	88	8,4	M 10	7 650	8 150	3,13	LQCD 25-2LS
30	68	47	32	64	50,5	26	158	180	96	10,5	M 12	12 200	12 900	4,43	LQCD 30-2LS
40	80	62	40	80	64	34	202	230	122	13,5	M 16	20 800	20 800	8,70	LQCD 40-2LS
50	100	75	48	96	80	34	250	280	152	13,5	M 16	30 000	28 000	15,55	LQCD 50-2LS

Upon request LQCR/LQCD bearing units are available in stainless steel execution.

Designation: e.g. LQCR/LQCD 20-2LS/HV6

For suitable shaft blocks for these bearing units, designation LEAS..A and LEAS..B, see page 41 of this catalogue.

¹⁾ Unit with LBAR8-LS linear ball bearing not designed for regreasing, non self-aligning.

²⁾ For 4 cylindrical screws with internal hexagon to DIN 912 / ISO 4762.

LQCF quadro linear bearing units

with LBCF .. A self-aligning linear ball bearings and open housing, can be relubricated.

F_w 12-50 mm

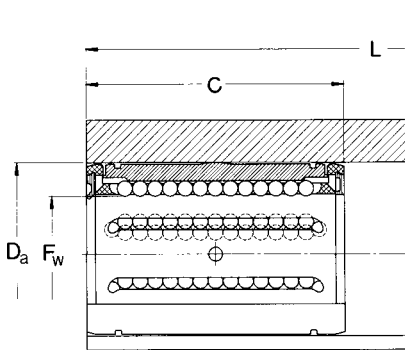

Linear bearing unit with seals

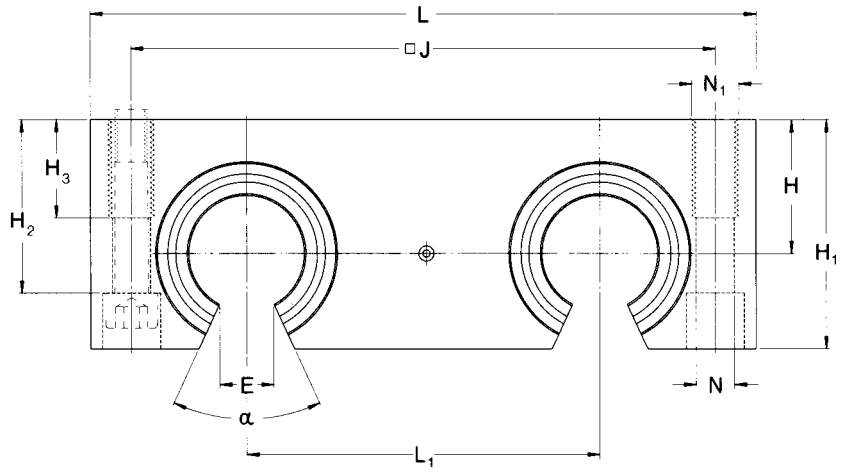

LQCF..2LS design

Dimensions														Basic load ratings		Mass	Designations
F_w	C	D_a	H $\pm 0,01$	H_1	H_2	H_3	J	L	L_1	$N^{2)}$	$N_1^{2)}$	$E^{1)}$	α	dyn. C	stat. C_0	kg	Linear bearing unit with double lip seals
mm												mm	Deg. N			kg	—
12	32	22	18	30	23,4	13	73	85	42	5,3	M 6	7,6	78	2 850	3 250	0,45	LQCF 12-2LS
16	36	26	22	35	28,4	13	88	100	54	5,3	M 6	10,4	78	3 450	3 450	0,73	LQCF 16-2LS
20	45	32	25	42	33,5	18	115	130	72	6,6	M 8	10,8	60	5 200	5 500	1,48	LQCF 20-2LS
25	58	40	30	51	40	22	140	160	88	8,4	M 10	13,2	60	7 650	8 150	2,68	LQCF 25-2LS
30	68	47	35	60	46,5	26	158	180	96	10,5	M 12	14,2	50	12 200	12 900	3,95	LQCF 30-2LS
40	80	62	45	77	61	34	202	230	122	13,5	M 16	18,7	50	20 800	20 800	8,12	LQCF 40-2LS
50	100	75	55	93	77	34	250	280	152	13,5	M 16	23,6	50	30 000	28 000	14,52	LQCF 50-2LS

Upon request LQCF bearing units are available in stainless steel execution.

Designation: e.g. LQCF 20-2LS/HV6

For suitable shaft supports for these bearing units, designation LRCB., see page 42 of this catalogue.

¹⁾ Smallest sector width at diameter F_w .

²⁾ For 4 cylindrical screws with internal hexagon to DIN 912 / ISO 4762.

Shaft carriers

Among shaft carriers, a distinction is made between shaft blocks and shaft supports. With shaft blocks the shaft is supported only at its ends; shaft supports run for the whole length or at least partially and therefore require the use of open linear bearing units.

LSCS/LSNS/LSHS shaft blocks

LSCS shaft blocks are made of cast aluminium. The individual elements grip the shaft at the end. They are supplied as standard with two screw holes in the shaft block base for attachment. LSCS shaft blocks are suitable for shaft diameters from 8 to 80 mm. LSNS and LSHS shaft blocks are made of extruded aluminium. Attachment is made by through bolts

or direct into the threaded holes on the underside. LSNS and LSHS shaft blocks are available for shaft of diameter 12 to 50 mm.

LEBS/LEAS tandem shaft blocks

To match the duo and quadro linear bearing units with linear ball bearings LBB of Series 1, LEBS tandem shaft blocks are available in the A design (i.e. fixed shaft blocks, linear bearing unit axially moveable). LEBS shaft blocks are available for shafts of diameter 12 to 50 mm. For units with linear ball bearings LBC/LBH of Series 3, LEAS tandem shaft blocks are available in A and B design. The B design allows axial movement of the shafts through a fixed linear bearing unit. LEAS shaft blocks are

available for shafts of diameter 8 to 50 mm.

LRCB/LRCC shaft supports

For heavily loaded linear bearing units and/or long track lengths, allowance must often be made for a high degree of bending of the shaft. In such cases continuous or at least partial support of the shaft is called for, with the use of open linear bearing units. SKF offers shaft supports for shaft diameters from 12 to 80 mm of the LRCB (with holes already drilled) and LRCC types (without holes).

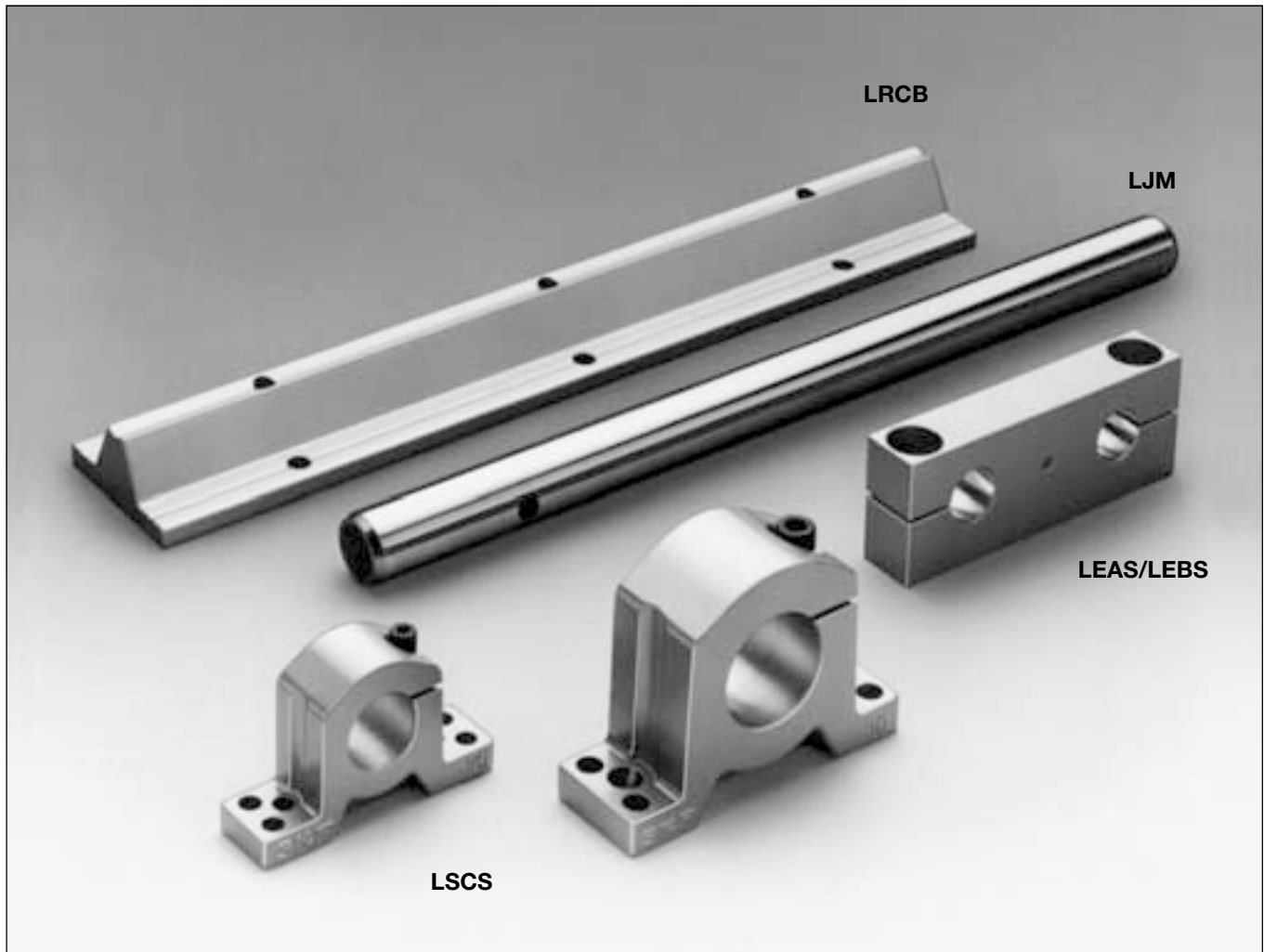

LSCS shaft blocks

d_a 8-80 mm

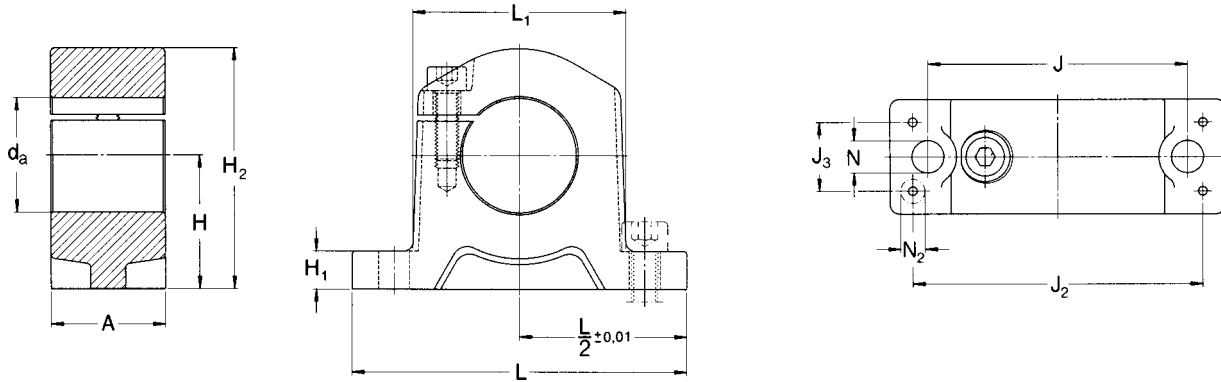

Dimensions												Mass	Designations
d_a	A	H $\pm 0,01$	H_1	H_2	J	J_2	J_3	L	L_1	$N^{1)}$	N_2		Shaft block
mm												kg	—
8	10	15	5,5	25	25	35	5	45	19	4,3	2,7	0,012	LSCS 8
12	12	20	6	32,5	32	42	6	52	25	5,3	3,2	0,023	LSCS 12
16	15	20	7	35,5	40	46	7,5	56	31,8	5,3	4,3	0,034	LSCS 16
20	20	25	8	43,5	45	58	10	70	37	5,3	5,3	0,065	LSCS 20
25	28	30	10	53	60	68	16	80	48	6,4	6,4	0,14	LSCS 25
30	30	35	10	63	68	76	18	88	56	8,4	6,4	0,20	LSCS 30
40	36	45	12	81	86	94	22	108	71	10,5	8,4	0,47	LSCS 40
50	49	50	14	92,5	108	116	30	135	86	10,5	10,5	0,68	LSCS 50
60	62	60	18	112	132	138	40	160	105	13	13	1,29	LSCS 60
80	85	80	22	147,5	170	180	60	205	136	17	15	3,01	LSCS 80

¹⁾ For screws with internal hexagon to DIN 912 / ISO 4762.

LSNS/LSHS shaft blocks

d_a 12-50 mm

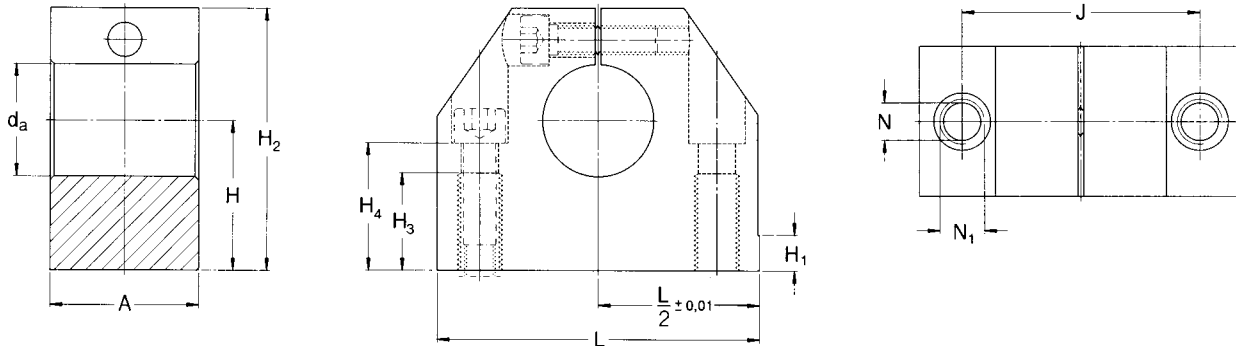

Dimensions										Mass	Designations		
d_a	A	H $\pm 0,01$	H_1	H_2	H_3	H_4	J	$L^{2)}$	$N^{1)}$	$N_1^{1)}$	kg	Shaft block	
mm											—	—	
12	20	20	6	35	13	16,5	30	43	5,3	M 6	0,06	LSNS 12	
16	24	25	7	42	18	21	38	53	6,6	M 8	0,11	LSNS 16	
20	30	30	7,5	50	22	25	42	60	8,4	M 10	0,17	LSNS 20	
25	38	35	8,5	61	26	30	56	78	10,5	M 12	0,34	LSNS 25	
30	40	40	9,5	70	26	34	64	87	10,5	M 12	0,46	LSNS 30	
40	48	50	11	90	34	44	82	108	13,5	M 16	0,90	LSNS 40	
50	58	60	11	105	43	49	100	132	17,5	M 20	1,45	LSNS 50	
12	18	19	—	33	13	16,5	27	40	5,3	M 6	0,05	LSHS 12	
16	20	22	—	38	13	18	32	45	5,3	M 6	0,07	LSHS 16	
20	24	25	—	45	18	21	39	53	6,6	M 8	0,11	LSHS 20	
25	28	31	—	54	22	25	44	62	8,4	M 10	0,17	LSHS 25	
30	30	34	—	60	22	29	49	67	8,4	M 10	0,22	LSHS 30	
40	40	42	—	76	26	37	66	87	10,5	M 12	0,47	LSHS 40	
50	50	50	—	92	34	44	80	103	13,5	M 16	0,82	LSHS 50	

Attention:

LSHS Shaft Blocks can be installed only in conjunction with the LBB Compact Series (page 4 to 13)!

¹⁾ For screws with internal hexagon to DIN 912 / ISO 4762.

²⁾ Tolerance $L/2 \pm 0,01$ only by execution LSNS.

LEBS tandem shaft blocks

d_a 12-50 mm

LEAS tandem shaft blocks

d_a 8-50 mm

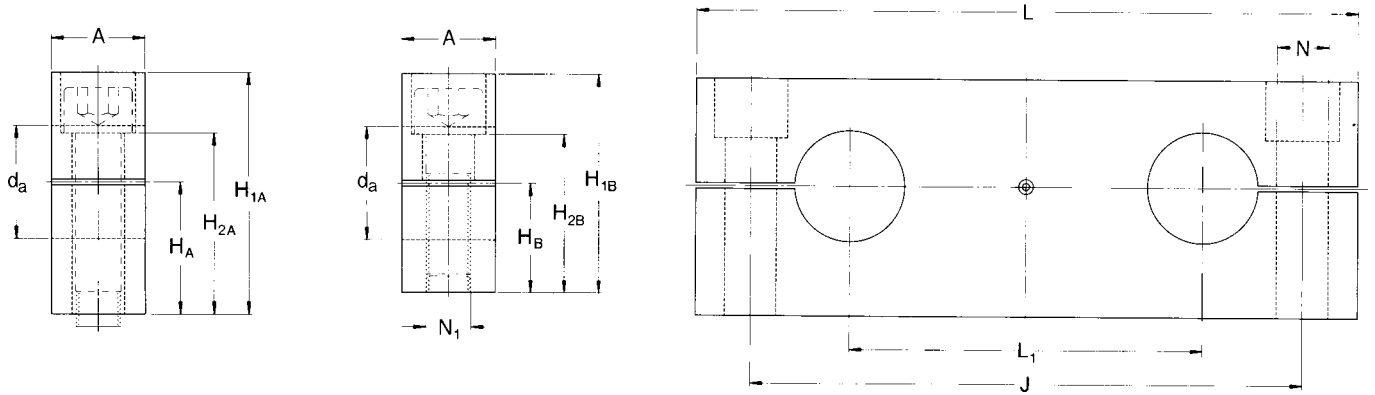

A design

B design

Dimensions										Mass		Designations				
d_a	A	H_A $\pm 0,015$	H_{1A}	H_B $\pm 0,015$	H_{1B}	H_{2A}	H_{2B}	J	L	L_1	$N^{1)}$	$N_1^{1)}$	Design A	B	Tandem shaft block Design A	B
mm													kg		—	
12	15	17	30	—	—	21,5	—	64	80	40	6,6	—	0,08	—	LEBS 12 A	—
16	15	19,5	35	—	—	26,5	—	80	96	52	6,6	—	0,11	—	LEBS 16 A	—
20	18	22	40	—	—	29	—	97	115	63	9	—	0,17	—	LEBS 20 A	—
25	20	27	50	—	—	36,5	—	115	136	75	11	—	0,28	—	LEBS 25 A	—
30	20	31	56	—	—	42,5	—	125	146	80	11	—	0,32	—	LEBS 30 A	—
40	25	38	70	—	—	54	—	160	184	97	13,5	—	0,63	—	LEBS 40 A	—
50	30	43	80	—	—	59	—	180	210	107	17,5	—	0,90	—	LEBS 50 A	—
8	12	12,5	23	11	22	16	15	52	65	32	5,5	M 5	0,04	0,04	LEAS 8 A	LEAS 8 B
12	14	18	32	14	28	23,5	19,5	70	85	42	6,6	M 6	0,09	0,07	LEAS 12 A	LEAS 12 B
16	18	20	36	17	34	26,5	23,5	82	100	54	9	M 8	0,14	0,13	LEAS 16 A	LEAS 16 B
20	20	25	46	21	42	32,5	28,5	108	130	72	11	M 10	0,25	0,22	LEAS 20 A	LEAS 20 B
25	25	30	56	26	52	40	36	132	160	88	13,5	M 12	0,47	0,44	LEAS 25 A	LEAS 25 B
30	25	35	64	29	58	48	42	150	180	96	13,5	M 12	0,62	0,56	LEAS 30 A	LEAS 30 B
40	30	44	80	36	72	59	51	190	230	122	17,5	M 16	1,15	1,00	LEAS 40 A	LEAS 40 B
50	30	52	96	44	88	75	67	240	280	152	17,5	M 16	1,70	1,52	LEAS 50 A	LEAS 50 B

Attention:

LEBS Tandem Shaft Blocks can be installed only in conjunction with the LBB Compact Series (page 4 to 13)!

¹⁾ For screws with internal hexagon to DIN 912 / ISO 4762.

LRCB/LRCC shaft supports

d 12-80 mm

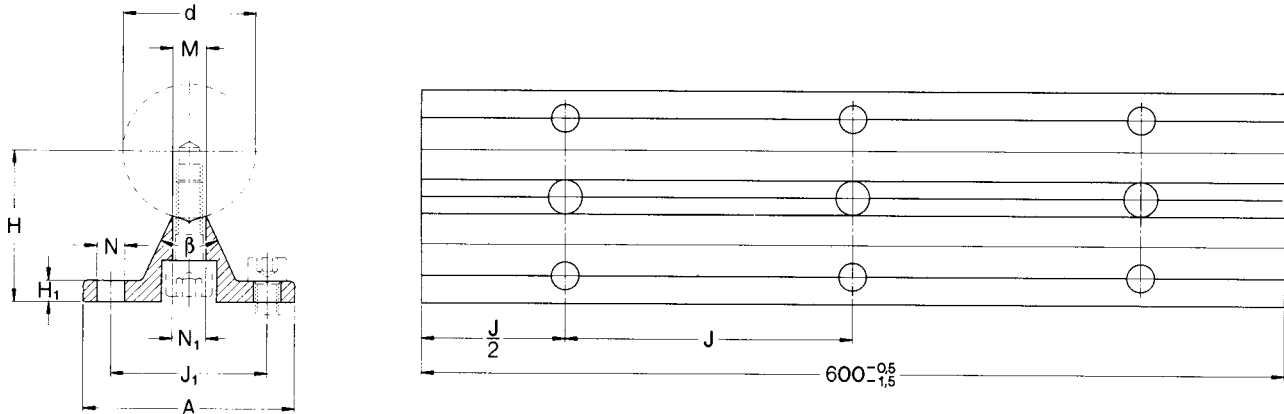

Shaft support
with bore holes LRCB design

Shaft Shaft support										Mass	Designations			
Dimensions											LRCB design	Shaft support with bore holes	Shaft support without bore holes	Shaft attachment ²⁾
d	A	H	H ₁	J	J ₁	M	N ¹⁾	N ₁ ²⁾	β	kg	—	—	Screw	Spring washer
mm	mm	±0,02							Deg.		—	—		
12	40	22	5	75	29	5,8	4,5	4,5	50	0,53	LRCB 12	LRCC 12	M 4x16	4
16	45	26	5	100	33	7	5,5	5,5	50	0,64	LRCB 16	LRCC 16	M 5x20	5
20	52	32	6	100	37	8,3	6,6	6,6	50	0,92	LRCB 20	LRCC 20	M 6x25	6
25	57	36	6	120	42	10,8	6,6	9	50	1,08	LRCB 25	LRCC 25	M 8x25	8
30	69	42	7	150	51	11	9	11	50	1,41	LRCB 30	LRCC 30	M 10x30	10
40	73	50	8	200	55	15	9	11	50	1,85	LRCB 40	LRCC 40	M 10x35	10
50	84	60	9	200	63	19	11	13,5	46	2,45	LRCB 50	LRCC 50	M 12x40	12
60	94	68	10	300	72	25	11	15,5	46	3,25	LRCB 60	LRCC 60	M 14x45	14
80	116	86	12	300	92	34	13,5	17,5	46	4,40	LRCB 80	LRCC 80	M 16x55	16

¹⁾ For screws with internal hexagon to DIN 912 / ISO 4762 without spring washers.

²⁾ For screws with internal hexagon to DIN 912 / ISO 4762 with spring washers to DIN 7980.

Quadro-Linear tables

LZBU quadro-linear tables

The closed LZBU quadro-linear table consists of a closed quadro linear bearing unit, two tandem shaft blocks and two shafts of the required length. The bearing unit is fitted with four LBCD .. A-LS self-aligning linear ball bearings each sealed on one side. The LZBU .. A design permits axial movement of the linear bearing unit, i.e. the shafts are fixed, to the machine bed via the LEAS..A shaft blocks. The LZBU..B design is provided with LEAS..B shaft blocks. This combination allows the shafts to travel with the shaft blocks in applications where the linear bearing unit is fixed.

LZBU quadro-linear tables can be supplied in sizes 8 to 50 mm. Size 8

tables are however not self-aligning and they are not designed for relubrication.

The description of the closed quadro-linear tables also applies to the combination of LQBR..2LS quadro-linear bearing units of Series 1 with twin LEBS tandem shaft blocks and shafts with a diameter of 12 to 50 mm.

LZAU quadro-linear tables

The open LZAU quadro-linear comprises the open quadro-linear unit and two high precision shafts with shaft supports. The bearing unit is fitted with four LBCF .. A-LS self-aligning linear ball bearings, each sealed at one side. The standard

lengths of these tables is dictated by the pitch of the attachment holes in the LRCB shaft supports. The total length should always be a multiple of this distance.

LZAU quadro-linear tables are available in sizes 12 to 50 mm.

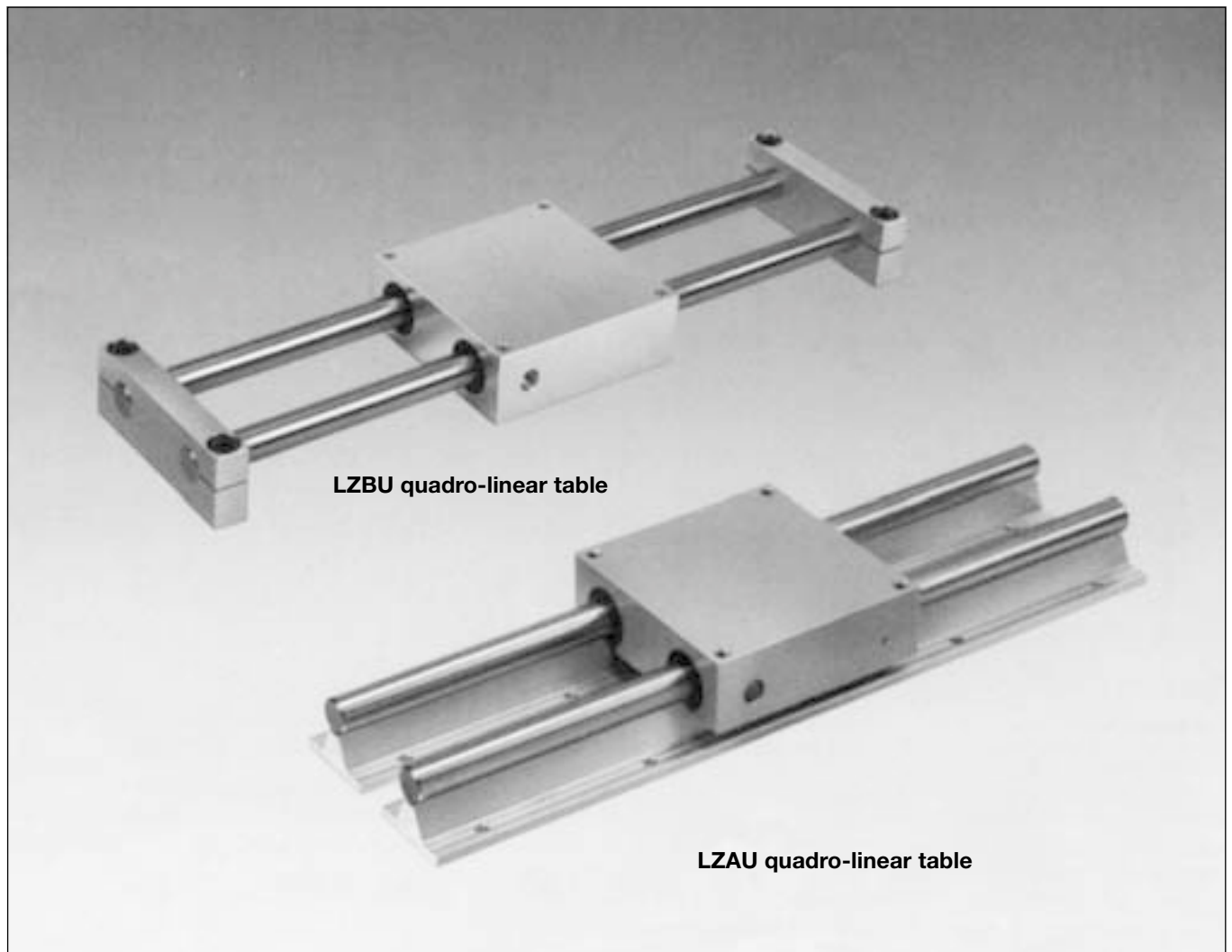

LZBU/LZAU quadro-linear tables non-driven
d 8-50 mm

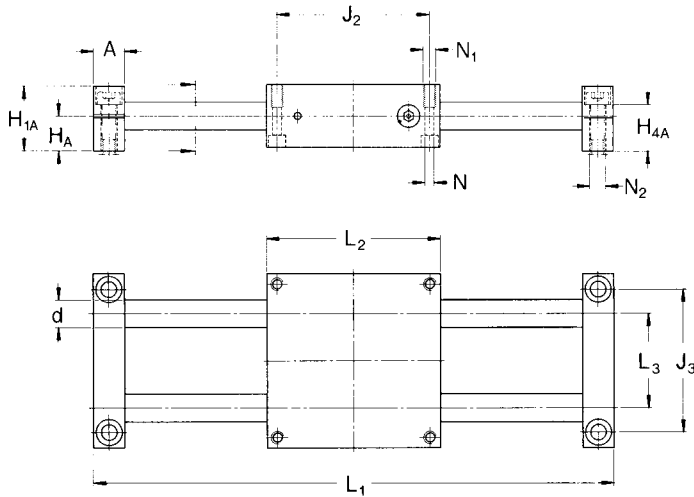

Design LZBU..A with closed linear bearing unit

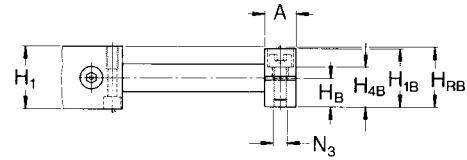
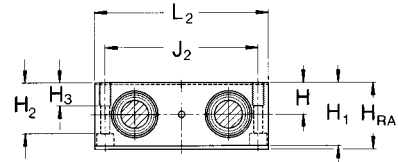

Design LZBU..B with closed linear bearing unit

Dimensions

Linear table					Linear bearing unit with self-aligning linear ball bearings										Shaft block					
d	H _{RA} ±0,03	H _{RB} ±0,03	H _T ±0,03	L ₁ ³⁾	L ₂	H	H ₁	H ₂	H ₃	H ₅	H ₆ ±0,01	H ₇	J ₂	N ⁴⁾	N ₁ ⁴⁾	A	H _A ±0,015	H _B ±0,015	H _{1A}	H _{1B}
mm															— mm					
8	24	22,5	—	600	65	11,5	23	17,5	11	—	—	—	55	4,3	M 5	12	12,5	11	23	22
12	34	30	40	900	85	16	32	25	13	23,4	18	30	73	5,3	M 6	14	18	14	32	28
16	38	35	48	1 500	100	18	36	29	13	28,4	22	35	88	5,3	M 6	18	20	17	36	34
20	48	44	57	1 800	130	23	46	37,5	18	33,5	25	42	115	6,6	M 8	20	25	21	46	42
25	58	54	66	1 800	160	28	56	45	22	40	30	51	140	8,4	M 10	25	30	26	56	52
30	67	61	77	2 400	180	32	64	50,5	26	46,5	35	60	158	10,5	M 12	25	35	29	64	58
40	84	76	95	3 000	230	40	80	64	34	61	45	77	202	13,5	M 16	30	44	36	80	72
50	100	92	115	3 000	280	48	96	80	34	77	55	93	250	13,5	M 16	30	52	44	96	88

- 1) The designation for an LZBU quadro-linear table with shaft diameter 20 mm, total length 1200 mm, tandem shaft blocks type A and quadro linear bearing unit, for instance, is LZBU 20 A-LS x 1200. Delivered as a kit of parts.
- 2) The designation for an LZAU quadro-linear table with shaft diameter 20 mm, total length 600 mm and quadro linear bearing unit, for instance, is LZAU 20-2LS x 600. Delivered with shafts and shaft supports ready assembled.
- 3) Any fixed length up to L1 is available for LZBU quadro-linear slides. Longer lengths are available to order. Length tolerance of shafts is to DIN 7168 coarse series.
- 4) Suitable screws with internal hexagon to DIN 912 / ISO 4762.
- 5) The separation is always arranged symmetrically to half the table length.
- 6) Valid only for even loading of all four LBC .. A linear ball bearings.
- 7) Units fitted with LBCR .. A linear ball bearings are not designed for relubrication and are non self-aligning.

LZBU/LZAU quadro-linear tables non-driven

12-50 mm

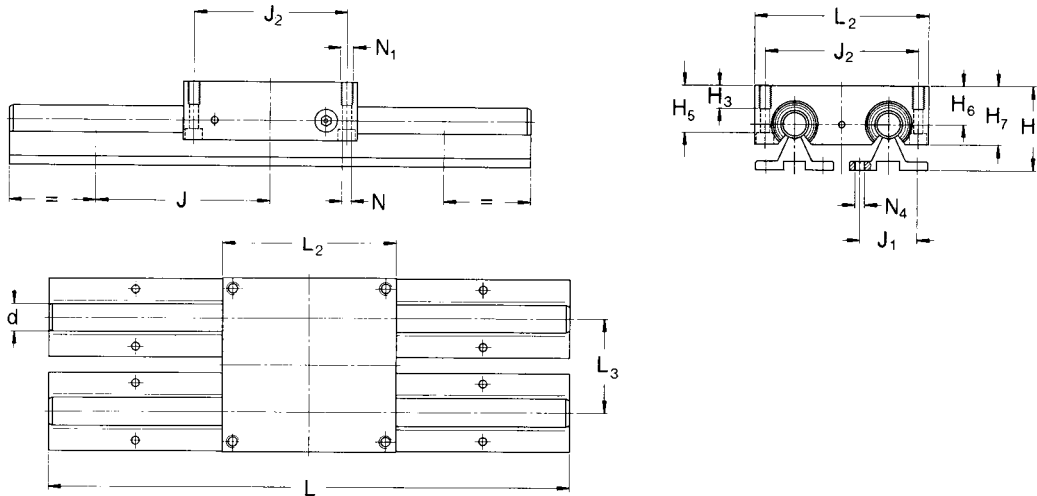

Design LZAU with open linear bearing unit

Dimensions			Load ratings ⁶⁾		Designations		Designations											
Shaft block			Shaft support		Bearing unit		Linear table ¹⁾		Linear table ²⁾									
d	H _{4A}	H _{4B}	J ₃	L ₃	N ₂ ⁴⁾	M	N ₃ ⁴⁾	J ⁵⁾	J ₁	N ₄ ⁴⁾	C	stat.	C ₀	closed bearing unit	Shaft block A	Shaft block B	open	Bearing unit
mm	—										mm	N	—					
8	16	15	52	32	5,5	M 5	—	—	—	—	1 290	1 420	—	LZBU 8 A-2LS ⁷⁾ LZBU 8 B-2LS ⁷⁾ —				
12	23,5	19,5	70	42	6,6	M 6	75	29	4,5	2 850	3 250	—	—	LZBU 12 A-2LS	LZBU 12 B-2LS	LZAU 12-2LS		
16	26,5	23,5	82	54	9	M 8	100	33	5,5	3 450	3 450	—	—	LZBU 16 A-2LS	LZBU 16 B-2LS	LZAU 16-2LS		
20	32,5	28,5	108	72	11	M 10	100	37	6,6	5 200	5 500	—	—	LZBU 20 A-2LS	LZBU 20 B-2LS	LZAU 20-2LS		
25	40	36	132	88	13,5	M 12	120	42	6,6	7 650	8 150	—	—	LZBU 25 A-2LS	LZBU 25 B-2LS	LZAU 25-2LS		
30	48	42	150	96	13,5	M 12	150	51	9	12 200	12 900	—	—	LZBU 30 A-2LS	LZBU 30 B-2LS	LZAU 30-2LS		
40	59	51	190	122	17,5	M 16	200	55	9	20 800	20 800	—	—	LZBU 40 A-2LS	LZBU 40 B-2LS	LZAU 40-2LS		
50	75	67	240	152	17,5	M 16	200	63	11	30 000	28 000	—	—	LZBU 50 A-2LS	LZBU 50 B-2LS	LZAU 50-2LS		

Dimensions

Standard length

d L

mm	length increments in mm										—	
12	300	600	900	1200	1500	1800	2100	2400	2700	3000	LZAU 12-2LS	—
16	300	600	900	1200	1500	1800	2100	2400	2700	3000	LZAU 16-2LS	—
20	300	600	900	1200	1500	1800	2100	2400	2700	3000	LZAU 20-2LS	—
25	300	600	900	1200	1500	1800	2100	2400	2700	3000	LZAU 25-2LS	—
30	300	600	900	1200	1500	1800	2100	2400	2700	3000	LZAU 30-2LS	—
40	300	600	900	1200	1500	1800	2100	2400	2700	3000	LZAU 40-2LS	—
50	—	600	900	1200	1500	1800	2100	2400	2700	3000	LZAU 50-2LS	—

Precision shafts

SKF precision shafts can be supplied either as solid or hollow shafts. The solid shafts are available in all dimensions required to fit SKF linear ball bearings; the hollow shafts have a minimum outer diameter of 16 mm. They are induction hardened and ground (see table on next page).

SKF shafts have exceptionally high dimensional stability and long service life. The only exception to this is at the end of shafts of normal production length deviations in hardness and dimensional stability can occur.

For special applications, solid shafts of stainless steel or hard chromium plated shafts having a chromium layer of approximately 10 μm thickness can be supplied. When using stainless steel shafts, it should be remembered that the surface is not as hard as that of shafts made of

high grade steel. The case depth may also be greater than indicated in the table and this may have an influence on the machinability of the shafts.

Because of the benefits they offer, SKF precision shafts are not only used together with SKF linear ball bearings for linear guides, but are also use for other purposes, for instance axles or column sleeves.

Materials

SKF precision shafts are made from the non-alloyed high-grade steels Cf53 (Material No.1.1213), Ck53 (Material No.1.1210), Ck60 (Material No.1.1221) and 100Cr6 (Material No.12067). The surface hardness is between approximately 60 and 64 HRC. The solid shafts of stainless steel are made from the steel X90CrMoV18

(Material No.1.4112) or X46Cr13 (Material No.1.4034). In this case the surface hardness lies between approximately 52 and 56 HRC. Shafts made from other materials can be supplied to special order.

Surface finish

All SKF precision steel shafts of hardenable steel have a surface roughness of max. 0,3 μm R_a (DIN 4768, Part 1).

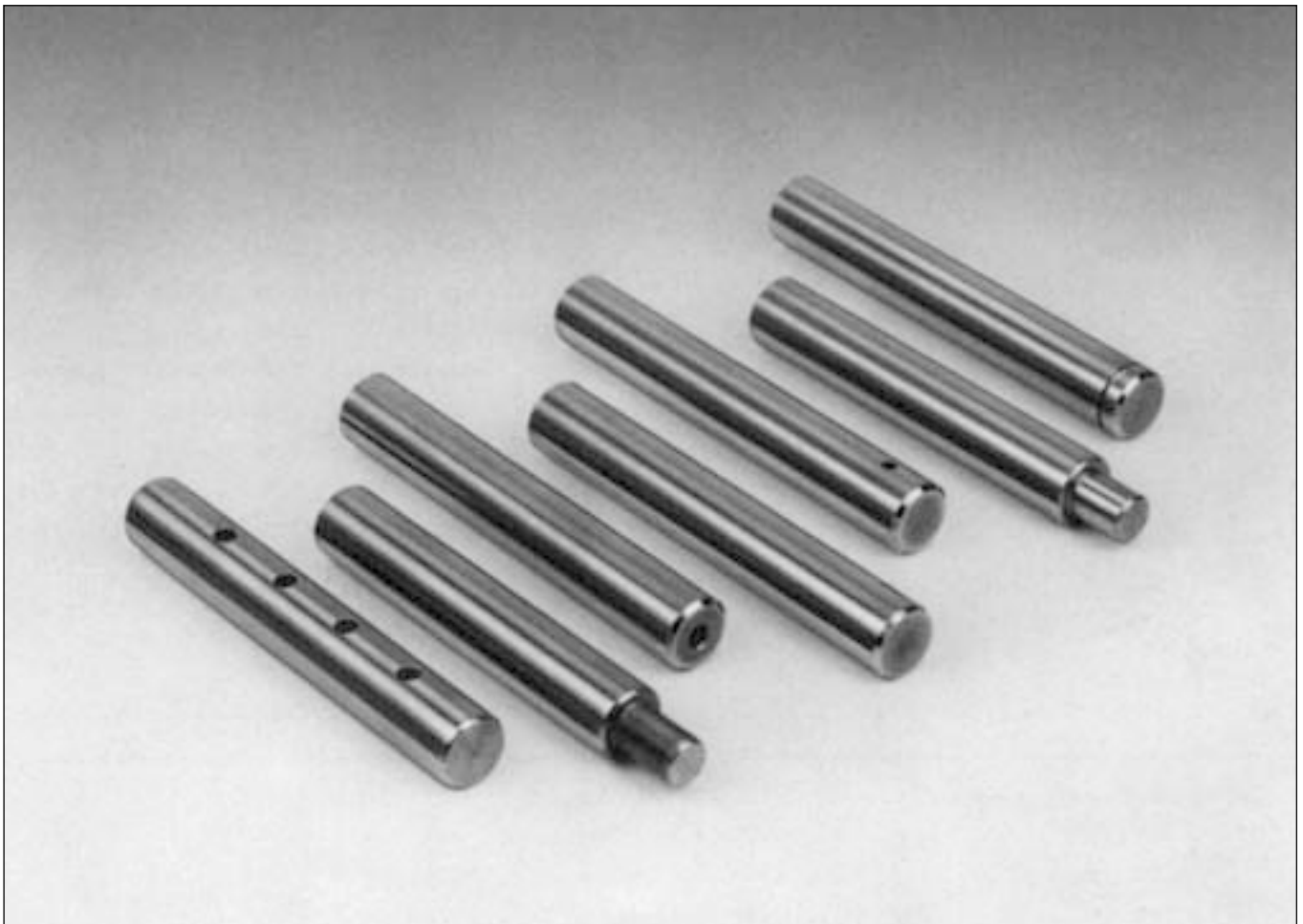

Case depth of SKF shafts

Shaft diameter		Case depth
over	incl	min
mm		mm
—	10	0,5
10	18	0,8
18	30	1,2
30	50	1,5
50	80	2,2
80	100	3,0

Tolerances

SKF precision steel shafts are available as standard with a diameter machined to tolerance h6 or h7. The accuracy of dimensions and form of these shafts will be found in the table on page 51. There may be slight deviations from the values given in the tables for sections of shaft which are soft annealed. SKF precision steel shafts with diameters machined to tolerance h9 can be supplied to special order. Shafts cut to special lengths have a length tolerance to DIN 7168 "medium". The relevant values are given in the adjacent table.

Shafts with radial holes

For linear guides requiring support, shafts with threaded radial holes are needed. These can be supplied by SKF. The radial holes may be either positioned to fit SKF shaft supports or as specified on customer's own drawings. It is however recommended that the guideline values given in the adjacent table for thread size and depth be followed. SKF shafts with radial holes are not soft annealed at the drilling position; the thread is out in the hardened and ground shaft. By this means changes in hardness and accuracy of the shaft are avoided.

Composite shafts

Composite shafts can be supplied to customer drawings, either with screwed joints (see illustrations, page 48) or with 'plug and socket' joints, depending on the application. Accurately centred trunnions and sockets guarantee smooth transitions at the butt joint. To ensure correct assembly, the relative positions of the shaft sections and of the shaft ends are marked. Composite shafts should be fastened to a support at the butt joints, particularly when these are of the 'plug and socket' type. The radial holes should also be positioned as close as possible to the joint and the length of the shaft be chosen so that any bending of the shaft will not cause a gap to be formed at the joint.

Length tolerances for shafts to DIN 7168, medium series

Nominal length		Deviation
over	incl	
mm		mm
—	120	± 0,3
120	400	± 0,5
400	1000	± 0,8
1000	2000	± 1,2
2000	4000	± 2
4000	8000	± 3

Corrosion protection, packing

SKF precision steel shafts are treated with a rust inhibiting preservative which must be removed before the shafts are installed. All shafts are individually packaged. Depending on size and quantity they are supplied in cardboard or wooden boxes which offer maximum protection during transport.

Standard length of the shafts

SKF precision steel shafts are available in following length

Shaft diameter	Standard length			
	LJM	LJMH	LJMR LJMS	LJT
mm	mm			
3/4**	100			
	200			
	300			
	400			
	500			
5	2800 - 4100			
6	2800 - 4100			
8	3500 - 4100	3500 - 4100	3500 - 4100	
10	3500 - 4100	3500 - 4100	3500 - 4100	
12	5100 - 6200	5100 - 6200	3500 - 4100	
14	5100 - 6200	5100 - 6200		
16	5100 - 6200	5100 - 6200	3500 - 4100	5100 - 6200
20	5100 - 6200	5100 - 6200	3500 - 4100	5100 - 6200
25	5100 - 6200	5100 - 6200	3500 - 4100	5100 - 6200
30	5100 - 6200	5100 - 6200	3500 - 4100	5100 - 6200
40	5100 - 6200	5100 - 6200	3500 - 4100	5100 - 6200
50	5100 - 6200	5100 - 6200	on request	5100 - 6200
60	5100 - 6200	5100 - 6200	on request	5100 - 6200
80	5100 - 6200	5100 - 6200	on request	5100 - 6200

* Different diameters and length on request.

** only available as ESSC 2 (see page 48).

ESSC Shafting standard

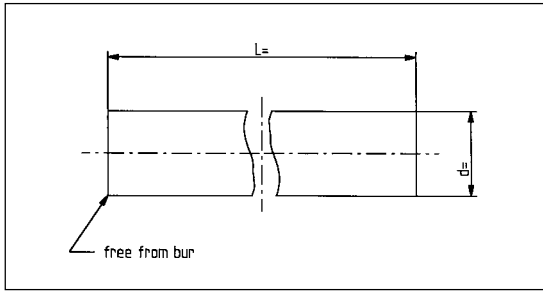

ESSC 1

cut with no chamfer only
deburr

- length tolerance according DIN 7168 middle range (see page 47)

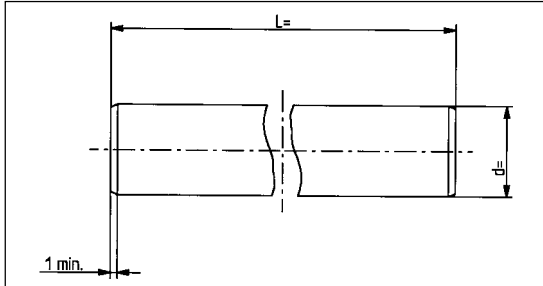

ESSC 2

cut with chamfer

- length tolerance as ESSC 1

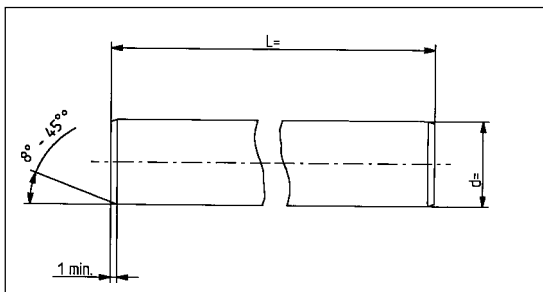

ESSC 3

cut with machined 25° chamfer and 90° front surfaces for limited length tolerance or chamfer according to customer specification

- length tolerance +/- 0,1 mm up to 3.000 mm total length

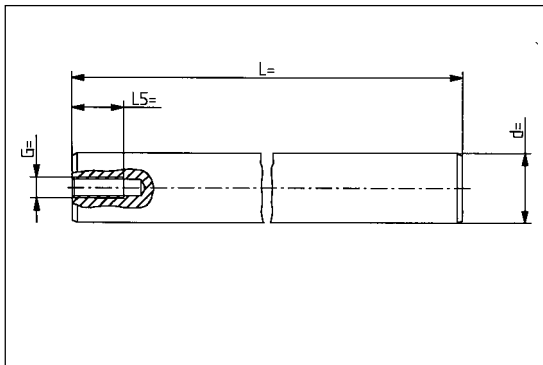

ESSC 4

cut with machined 25° chamfer, 90° front surfaces and one axial hole

- length tolerance as ESSC 3

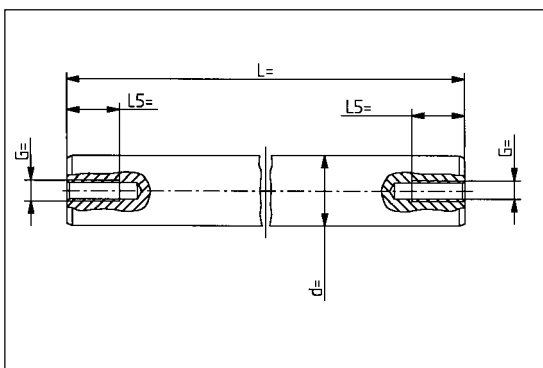

ESSC 5

as ESSC 4
with two axial holes

Dimensions of frontside thread

Ø (d)	Thread (G)	Depth (L5)
5	-	-
8	M4	10
10	M4	10
12	M5	12,5
14	M5	12,5
16	M6	15
20	M8	20
25	M10	25
30	M10	25
40	M12	30
50	M16	40
60	M20	50
80	M24	60

Dimensions of frontside thread

Ø (d)	Thread (G)	Depth (L5)
5	-	-
8	M4	10
10	M4	10
12	M5	12,5
14	M5	12,5
16	M6	15
20	M8	20
25	M10	25
30	M10	25
40	M12	30
50	M16	40
60	M20	50
80	M24	60

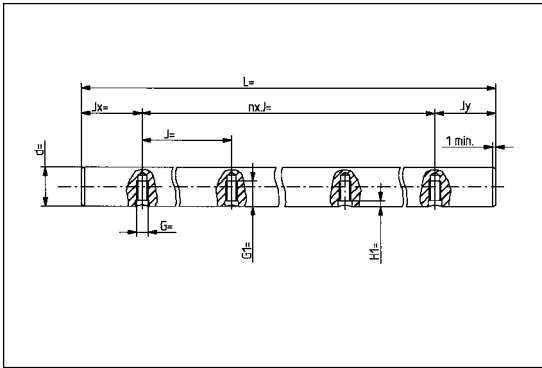

ESSC 6

cut and chamfer as ESSC 2

- with radial holes for LRCCB (see page 42)
- first radial hole with $J_x = J/2$
- H1 according to hardness depth

Dimensions of radial thread

Ø	Thread	G	G1	J	Jx
5	-	-	-	-	-
8	-	-	-	-	-
12	M4	5	8	75	37,5
16	M5	6	9,5	100	50
20	M6	7	13	100	50
25	M8	9	14	120	60
30	M10	11	18	150	75
40	M10	11	20	200	100
50	M12	13	23	200	100
60	M14	15	28	300	150
80	M16	16	33	300	150

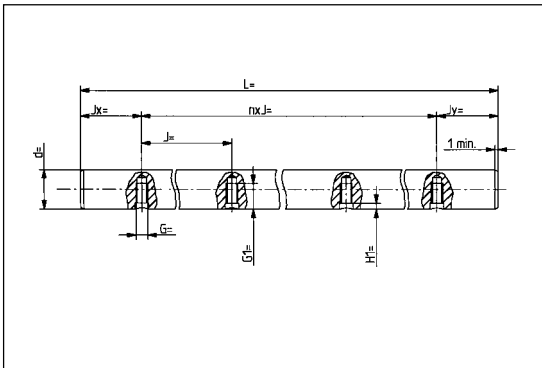

ESSC 7

as ESSC 6

- radial holes with J and Jx according to customer specification

Ø	Thread	G	G1	J	Jx
5	-	-	-	-	-
8	-	-	-	-	-
12	M4	5	8	-	-
16	M5	6	9,5	-	-
20	M6	7	13	-	-
25	M8	9	14	-	-
30	M10	11	18	-	-
40	M10	11	20	-	-
50	M12	13	23	-	-
60	M14	15	28	-	-
80	M16	16	33	-	-

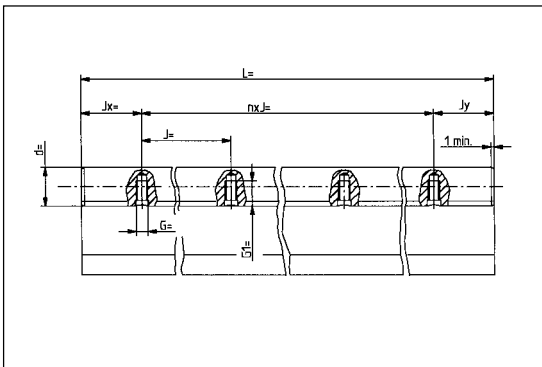

ESSC 8

cut and chamfer as ESSC 2

- Shaft is mounted on LRCCB (see page 42)
- first radial hole with $J_x = J/2$
- H1 according to hardness depth

Ø	Thread	G	G1	J	Jx
5	-	-	-	-	-
8	-	-	-	-	-
12	M4	5	8	75	37,5
16	M5	6	9,5	100	50
20	M6	7	13	100	50
25	M8	9	14	120	60
30	M10	11	18	150	75
40	M10	11	20	200	100
50	M12	13	23	200	100
60	M14	15	28	300	150
80	M16	16	33	300	150

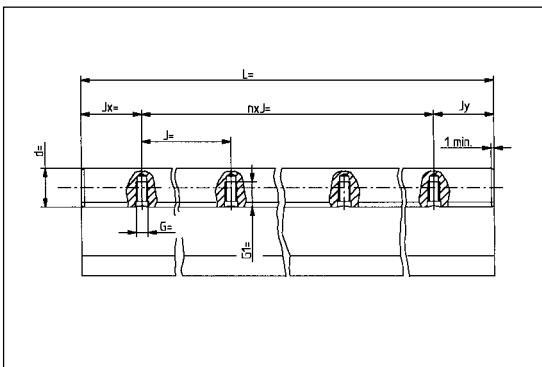

ESSC 9

as ESSC 8

- Shaft is mounted on LRCC (see page 42)
- radial holes with J and Jx according to customer specification

Ø	Thread	G	G1	J	Jx
5	-	-	-	-	-
8	-	-	-	-	-
12	M4	5	8	-	-
16	M5	6	9,5	-	-
20	M6	7	13	-	-
25	M8	9	14	-	-
30	M10	11	18	-	-
40	M10	11	20	-	-
50	M12	13	23	-	-
60	M14	15	28	-	-
80	M16	16	33	-	-

ESSC 10

shaft according to customer specification

- drawing is obligatory of manufacturing

Precision shafts

d 5-80 mm

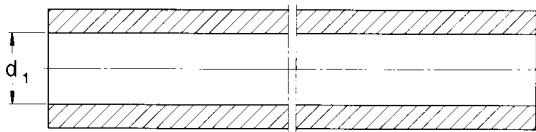
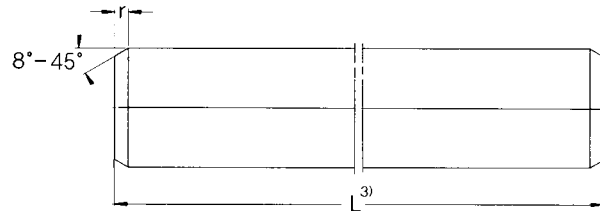
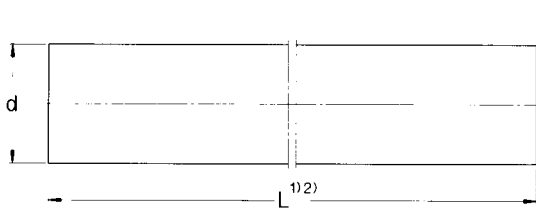

Standard designs
Designs for fixed lengths
without chamfer

Designs for fixed length
with chamfer

Dimension			Mass		Moment of inertia		Cross sectional area		Designations				
d	d ₁	r _{min}	Solid shaft	Hollow shaft	Solid shaft	Hollow shaft	Solid shaft	Hollow shaft	Solid shafts of precision steel	Solid shafts of stainless steel X90CrMoV18	X46Cr13	Solid shafts with high grade steel hard chromium plated	Hollow shaft high grade steel
mm			kg/m		cm ⁴		mm ²						
3	—	0,4	0,06	—	0,0004	—	7,1	—	LJM 3				
4	—	0,4	0,1	—	0,0013	—	12,6	—	LJM 4				
5	—	0,8	0,15	—	0,0031	—	19,6	—	LJM 5				
6	—	0,8	0,22	—	0,0064	—	28,3	—	LJM 6				
8	—	0,8	0,39	—	0,020	—	50,3	—	LJM 8	LJMR 8	LJMS 8	LJMH 8	
10	—	0,8	0,62	—	0,049	—	78,5	—	LJM 10	LJMR 10	LJMS 10	LJMH 10	
12	—	1	0,89	—	0,102	—	113	—	LJM 12	LJMR 12	LJMS 12	LJMH 12	
14	—	1	1,21	—	0,189	—	154	—	LJM 14			LJMH 14	
16	7	1	1,57	1,28	0,322	0,310	201	163	LJM 16	LJMR 16	LJMS 16	LJMH 16	LJT 16
20	12	1,5	2,45	1,26	0,785	0,597	314	160	LJM 20	LJMR 20	LJMS 20	LJMH 20	LJT 20
25	14	1,5	3,83	2,40	1,92	1,64	491	305	LJM 25	LJMR 25	LJMS 25	LJMH 25	LJT 25
30	19	1,5	5,51	3,55	3,98	3,46	707	453	LJM 30	LJMR 30	LJMS 30	LJMH 30	LJT 30
40	26	2	9,80	5,40	12,6	9,96	1260	685	LJM 40	LJMR 40	LJMS 40	LJMH 40	LJT 40
50	35	2	15,3	10,6	30,7	27,7	1960	1350	LJM 50	LJMR 50	LJMS 50	LJMH 50	LJT 50
60	36	2,5	22,1	15,1	63,6	57,1	2830	1920	LJM 60			LJMH 60	LJT 60
80	53	2,5	39,2	20,1	201	153	5030	2565	LJM 80			LJMH 80	LJT 80

Attention:

d₁ can deviate from the value quoted. Please enquire if necessary.

Different shaft diameters and types on request.

The static load capacity has to be decreased by 8% and the dynamic load capacity by 18% when using the nonrusting types (HV6) in conjunction with precision steel shafts made of stainless steel.

Shafts cut to special length with flat turned ends. The length tolerance of these shafts corresponds to DIN 7168, medium. The designation for a shaft with 20 mm diameter cut to a length of 1,5 m is, for example, LJM 20x1500.

Precision shafts of high-grade steel

d 5-80 mm

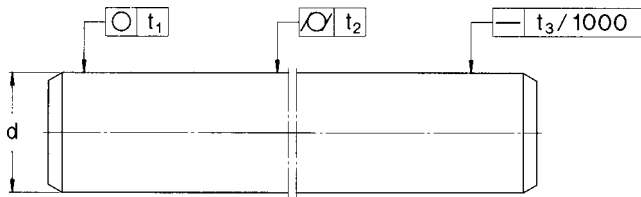

Shaft Nominal diameter d	Accuracy of dimension and form									
	Shafts to tolerance h6					Shafts to tolerance h7				
	Diameter deviation		Circularity	Cylindricity	Straightness ¹⁾	Diameter deviation		Circularity	Cylindricity	Straightness ¹⁾
mm	high	low	t_1	t_2	t_3	high	low	t_1	t_2	t_3
3	0	- 6	3	4	150	0	-10	4	6	150
4	0	- 8	4	5	150	0	-12	5	8	150
5	0	- 8	4	5	150	0	-12	5	8	150
6	0	- 8	4	5	150	0	-12	5	8	150
8	0	- 9	4	6	120	0	-15	6	9	120
10	0	- 9	5	7	120	0	-15	7	10	120
12	0	-11	5	8	100	0	-18	8	11	100
14	0	-11	5	8	100	0	-18	8	11	100
16	0	-11	5	8	100	0	-18	8	11	100
20	0	-13	6	9	100	0	-21	9	13	100
25	0	-13	6	9	100	0	-21	9	13	100
30	0	-13	6	9	100	0	-21	9	13	100
40	0	-16	7	11	100	0	-25	11	16	100
50	0	-16	7	11	100	0	-25	11	16	100
60	0	-19	8	13	100	0	-30	13	19	100
80	0	-19	8	13	100	0	-30	13	19	100

¹⁾ Shafts with straightness 50 $\mu\text{m}/1000$ mm to order

SKF Sales companies

Australia

SKF AUSTRALIA PTY. LTD
P. O. Box 301
OAKLEIGH, Victoria 3166
Phone: + 61 (3) 5 67 28 00
Fax: + 61 (3) 5 67 28 88

Austria

SKF ÖSTERREICH AG
Postfach 87
A-2355 WIENER NEUDORF
Phone: + 43 (22 36) 6 70 90
Fax: + 43 (22 36) 6 70 92 20

Benelux

SKF MULTITEC BENELUX B. V.
Kelvinbaan 16
NL-3439 MT NIEUWEGEIN
Phone: + 31 306 029 029
Fax: + 31 306 029 028
Phone: (B) + 32 2 5024270
Fax: (B) + 32 2 5027336

Canada

SKF CANADA LIMITED
40 Executive Court
SCARBOROUGH, ONTARIO
MIS 4 N 4
Phone: + 1 (4 16) 2 99 12 20
Fax: + 1 (4 16) 2 92 03 99

Czech Republic

SKF LOŽISKA A.S.
P. O. Box 19
U Městského pivovaru 7
17004 PRAHA 7
Phone: + 420 (0)2 66 19 71 11
Fax: + 420 (0)2 66 71 04 15

Denmark

SKF MULTITEC
Bramdrupskovvej 17
DK-6000 KOLDING
Phone: + 45 - 65 92 77 77
Phone: + 46 - 42 25 35 00
Fax: + 45 - 65 92 74 77

Finland

SKF MULTITEC
PL 60
FIN-02201 ESPOO
Phone: + 3 58 94 52 97 54
Fax: + 3 58 94 12 77 65

France

SKF EQUIPEMENTS
30/32 Ave. Des Trois Peuples
F-78185 SAINT QUENTIN
Yvelines Cedex
Phone: + 33 (1) 30 12 73 00
Fax: + 33 (1) 30 12 69 09

Germany

SKF LINEARSYSTEME GMBH
Parisstraße 1
97424 SCHWEINFURT
Phone: + 49 (97 21) 6 57 - 0
Fax: + 49 (97 21) 6 57 - 111

Great Britain

SKF ENGINEERING PRODUCTS LTD.
Sundon Park Road
Luton
BEDFORDSHIRE LU3 3BL
Phone: + 44 (15 82) 49 0049
Fax: + 44 (15 82) 49 6574

Hong Kong

SKF CHINA LIMITED
Unit A 35/F. Manulife Tower
169 Electric Road · North Point
HONG KONG
Phone: + 852 - 25 10 81 11
Fax: + 852 - 25 10 73 68

Hungary

SKF SVÉD GOLYÓSCSAPÁGY
RESZVENYTARSASAG
Csata u. 25
HU-2040 BUDAÖRS
Phone: + 36 (23) 41 59 96
Fax: + 36 (23) 41 59 28

Italy

SKF MULTITEC S.p. A.
Corso Vittorio Emanuele II, 94
I-10121 TORINO
Phone: + 39 (011) 57 17 61
Fax: + 39 (011) 5 71 76 33

Japan

SKF JAPAN LTD
9-1 1-Chome, Shiba Daimon
Minato - Ku
TOKYO 105
Phone: + 81 3 3436 4129
Fax: + 81 3 3578 1014

Norway

SKF MULTITEC A/S
Jerikoveien 14
1067 OSLO
N-1007 OSLO 10
Phone: + 47 (2) 2 30 71 70
Fax: + 47 (2) 2 30 28 14

Poland

SKF CENTRALA HANLOWO-
TECHNICZNA SP. ZO.O.
ul. Pulawska 303
02-785 WARSZAWA
Phone: + 48 22 549 4700
Fax: + 48 22 549 4701

Sweden

SKF MULTITEC AB
Ekslingan 3 · HELSINGBORG
Postal address: Box 222 48
S-25024 HELSINGBORG
Phone: + 46 (42) 25 35 00
Fax: + 46 (42) 25 35 45

Singapore

SKF SOUTH EAST ASIA &
PACIFIC PTE. LTD.
153 Gul Circle Jurong
Singapore 629610
Postal Address:
Jurong Point P. O. Box 445
SINGAPORE 916415
Phone: + 65 - 8 61 69 22
Fax: + 65 - 8 61 10 11

Spain/Portugal

SKF PRODUCTOS INDUSTRIALES S.A.
Apartado 769
E-08080 BARCELONA
Phone: + 34 (93) 3 77 99 77
Fax: + 34 (93) 4 74 20 39/31 56

Switzerland

SKF (SCHWEIZ)
Eschenstraße 5
CH-8603 SCHWERZENBACH
Phone: + 41 (1) 8 25 81 81
Fax: + 41 (1) 8 25 82 82

USA

SKF MOTION TECHNOLOGIES
1530 Valley Center Parkway
USA-BETHLEHEM, PA 18017
Phone: + 1 (610) 861 - 4800
Fax: + 1 (610) 861 - 4811



SKF Guiding Systems



SKF Ball & Roller Screws



SKF Actuators

SKF Linear Motion offers a wide range of precision engineered linear motion components, units and systems. In addition to comprehensive product literature and software, SKF offers assistance from experienced linear motion engineers.

Linear Motion has **3 product lines** and a sales organisation based on **11 specialized sales companies** located in Europe, Japan and in the USA.

However the product availability as well as the product application is **world-wide granted by the SKF Bearing international network**. To get any other SKF address all over the world, please contact one of the companies below.

Benelux

SKF Multitec Benelux B.V.

Phone: +31 30 6029029
Fax: +31 30 6029028
Für Belgien/Luxemburg:
Phone: +32 2 5024270
Fax: +32 2 5027336
e-mail: multitec_benelux@skf.com

Deutschland

SKF Linearsysteme GmbH

Phone: +49 9721 657-0
Fax: +49 9721 657-111
e-mail: lin.sales@skf.com

Frankreich

SKF Equipements

Phone: +33 1 30 12 73 00
Fax: +33 1 30 12 69 09
e-mail: equipements.france@skf.com

Großbritannien

SKF Engineering Products Ltd.

Phone: +44 1582 490049
Fax: +44 1582 496574
e-mail: skf.epl@skf.com

Italien

Multitec

SKF Industrie S.p.A.
Phone: +39 11 57 17 61
Fax: +39 11 5 71 76 33
e-mail: multitec.italy@skf.com

Japan

SKF Japan Ltd.

Phone: +81 3 3436 4129
Fax: +81 3 3578 1014
e-mail: skf.japan@skf.com

Österreich

SKF Linear Motion

SKF Österreich AG
Phone: +43 22 36 6 7090
Fax: +43 22 36 6 709220
e-mail: multitec.austria@skf.com

Schweiz

Linear Motion & Precision Technologies

Phone: +41 1 825 81 81
Fax: +41 1 825 82 82
e-mail: skf.schweiz@skf.com

Skandinavien

SKF Multitec Schweden

Phone: +46 42 25 35 00
Fax: +46 42 25 35 45/46

Verkaufsbüro Dänemark

Phone: +45 65 92 77 77
Fax: +45 65 92 74 77

Verkaufsbüro Finnland

Phone: +358 94 52 97 52
Fax: +358 94 12 77 65

Verkaufsbüro Norwegen

Phone: +47 22 30 71 70
Fax: +47 22 30 28 14
e-mail: multitec.nordic@skf.com

Spanien

SKF Productos Industriales S.A

Phone: +34 93 377 99 77
+34 93 377 99 07
Fax: +34 93 474 20 39/31 56
e-mail: prod.ind@skf.com

USA

SKF Motion Technologies

Phone: +1 610 861-4800
Fax: +1 610 861-4811
e-mail: motiontech.usa@skf.com

<http://www.linearmotion.skf.com>

