

CAHB-22E and -22S

Linear actuator



Benefits

- High productivity
- Reliability and safety
- Save development time
- Cost effectiveness
- Quick time to market (for Smart version)

Features

- High force
- High speed
- High holding force
- Mechanical overload protection
- Corrosion protection and stainless steel tube
- Manual override option
- Enhanced ingress protection, virtuality maintenance free

Smart version S features

- Integrated controller with complete motion control
- True absolute position contactless sensor
- Monitoring and onboard diagnostic (force, voltage, temperature)
- I/O and CAN bus SAE J1939 communication

Technical data

Designation	Unit	CAHB-22E / 12 V				CAHB-22E / 24 V			
Performance data									
Rated Push Force	N	2 300	3 500	6 800	10 000	2 300	3 500	6 800	10 000
Rated Pull Force	N	2 300	3 500	6 800	10 000	2 300	3 500	6 800	10 000
Max pull / push Force ¹⁾	N	3 500	4 900	9 500	14 000	3 500	4 900	9 500	14 000
Holding force ²⁾	N								
Speed without load ³⁾	mm/s	55,0	45,0	22,0	13,0	53,0	45,0	22,0	13,0
Speed with the rated force ³⁾	mm/s	42,0	36,0	15,5	10,2	42,0	37,0	17,0	10,2
Electric data									
Nominal voltage	V DC	12	12	12	12	24	24	24	24
Nominal current @ rated load ³⁾	A	18	19,5	19,5	19	8	9,5	9,5	8,5
Rated current (clutch activation)	A	24,3	25,5	25,5	25	10,6	12,3	12,3	10,9
Duty cycle	%	10 (85/765 s)	10 (85/765 s)	10 (85/765 s)	10 (85/765 s)	20 (85/340 s)	20 (85/340 s)	20 (85/340 s)	20 (85/340 s)
Mechanical data									
Stroke	mm	50 ... 700	50 ... 700	50 ... 610	50 ... 450	50 ... 700	50 ... 700	50 ... 610	50 ... 450
Backlash	mm	1,0	1,0	0,6	0,6	1,0	1,0	0,6	0,6
Weight for 200 mm stroke	kg	4,8	4,8	4,8	4,8	4,8	4,8	4,8	4,8
Colour	-	Black	Black	Black	Black	Black	Black	Black	Black
Environment and standards									
Ambient temperature ⁴⁾	°C	-40 ... 85	-40 ... 85	-40 ... 85	-40 ... 85	-40 ... 85	-40 ... 85	-40 ... 85	-40 ... 85
Degree of protection	-	IP 69K/66M							
Standards / EMC	-	EN61000-6-2:2005, EN61000-6-4:2007/A1:2011							
Salt spray test	-	ISO 9227:2012, 250 hours							

¹⁾ Upper limit of the pull/push force limited by the clutch. The lower limit is just above the rated force. The limitation of the force will happen between these 2 limits

²⁾ Ultimate Static Load, refer to the "Static load" diagrams

³⁾ The data of speed and current on this list is defined at +20 °C

⁴⁾ Full performance from 0 °C to +40 °C

Designation	Unit	CAHB-22E / 48 V			
Performance data					
Rated Push Force	N	2 300	3 500	6 800	10 000
Rated Pull Force	N	2 300	3 500	6 800	10 000
Max pull / push Force ¹⁾	N	3 500	4 900	9 500	14 000
Holding force ²⁾	N				
Speed without load ³⁾	mm/s	57,0	45,0	22,0	13,0
Speed with the rated force ³⁾	mm/s	50,0	37,0	18,5	10,2
Electric data					
Nominal voltage	V DC	48	48	48	48
Nominal current @ rated load ³⁾	A	4,5	5	5	4,3
Rated current (clutch activation)	A	6,5	7	7	5,5
Duty cycle	%	20 (85/340 s)	20 (85/340 s)	20 (85/340 s)	20 (85/340 s)
Mechanical data					
Stroke	mm	50 ... 700	50 ... 700	50 ... 610	50 ... 450
Backlash	mm	1,0	1,0	0,6	0,6
Weight for 200 mm stroke	kg	4,8	4,8	4,8	4,8
Colour	–	Black	Black	Black	Black
Environment and standards					
Ambient temperature ⁴⁾	°C	–40 ... 85	–40 ... 85	–40 ... 85	–40 ... 85
Degree of protection	–	IP 69K/66M			
Standards / EMC	–	EN61000-6-2:2005, EN61000-6-4:2007/A1:2011			
Salt spray test	–	ISO 9227:2012, 250 hours			

¹⁾ Upper limit of the pull/push force limited by the clutch. The lower limit is just above the rated force. The limitation of the force will happen between these 2 limits

²⁾ Ultimate Static Load, refer to the “Static load” diagrams

³⁾ The data of speed and current on this list is defined at +20 °C

⁴⁾ Full performance from 0 °C to +40 °C

Designation	Unit	CAHB-22S / 12 V				CAHB-22S / 24 – 48 V			
Performance data									
Rated Push Force	N	2 300	3 500	6 800	10 000	2 300	3 500	6 800	10 000
Rated Pull Force	N	2 300	3 500	6 800	10 000	2 300	3 500	6 800	10 000
Max pull / push Force ¹⁾	N	3 500	4 900	9 500	14 000	3 500	4 900	9 500	14 000
Holding force ²⁾	N								
Speed without load ³⁾	mm/s	55,0	45,0	22,0	13,0	53,0	45,0	22,0	13,0
Speed with the rated force ³⁾	mm/s	42,0	36,0	15,5	10,2	42,0	37,0	17,0	10,2
Electric data									
Nominal voltage ⁴⁾	V DC	12	12	12	12	24 – 48	24 – 48	24 – 48	24 – 48
Nominal current ³⁾	A	18,0	19,5	19,5	19,0	8,0 – 4,0	9,5 – 4,8	9,5 – 4,8	8,5 – 4,3
Max. current, rated current ⁵⁾	A	31,3	31,3	31,3	31,3	20,7 – 10,4	20,7 – 10,4	20,7 – 10,4	20,7 – 10,4
Duty cycle ⁶⁾	%	10	10	10	10	20	20	20	20
Mechanical data									
Stroke	mm	50 ... 700	50 ... 700	50 ... 610	50 ... 450	50 ... 700	50 ... 700	50 ... 610	50 ... 450
Backlash	mm	1,0	1,0	0,6	0,6	1,0	1,0	0,6	0,6
Max. manual override torque	Nm	1,0	1,0	1,0	1,0	1,0	1,0	1,0	1,0
Max. manual override speed	rpm	1 600	1 600	1 600	1 600	1 600	1 600	1 600	1 600
Weight for 200 mm stroke	kg	4,8	4,8	4,8	4,8	4,8	4,8	4,8	4,8
Colour	–	Black	Black	Black	Black	Black	Black	Black	Black
Environment and standards									
Ambient temperature ⁷⁾	°C	–40 ... 85	–40 ... 85	–40 ... 85		–40 ... 85	–40 ... 85	–40 ... 85	
Degree of protection	–	IP69K/66M							
Standards / EMC	–	EN61000-6-2:2005, EN61000-6-4:2007/A1:2011							
Salt spray test	–	ISO 9227:2012 500 hours							

¹⁾ Upper limit of the pull/push force, limited by the E-clutch.

²⁾ Ultimate static load, refer to the “Static load” diagrams.

³⁾ The data of speed and current on this list is defined temperature at +20°C, PWM 100%

⁴⁾ 12 V version use 12 V DC motor, 24 – 48 V version use 24 V DC motor.

⁵⁾ Max. current is the upper limit of the input current to the actuator. In any circumstances, the current will not exceed to max. current.

⁶⁾ Duty cycle is defined temperature at +20°C. 10% is 85 s on / 765 s off; 20% is 85 s on / 340 s off.

⁷⁾ Full performance from 0°C to +40°C

Performance diagrams

Speed-Load diagram

Speed [mm/s]

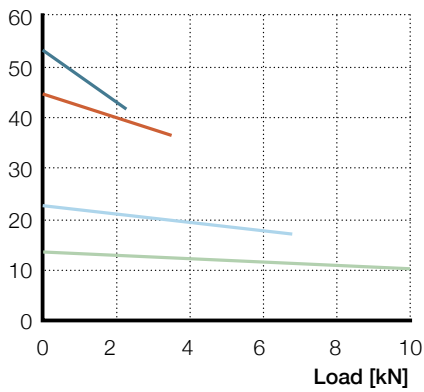

- CAHB-22-x1E
- CAHB-22-x2E
- CAHB-22-x3E
- CAHB-22-x4E

Current-Load diagram

Current consumption [A]

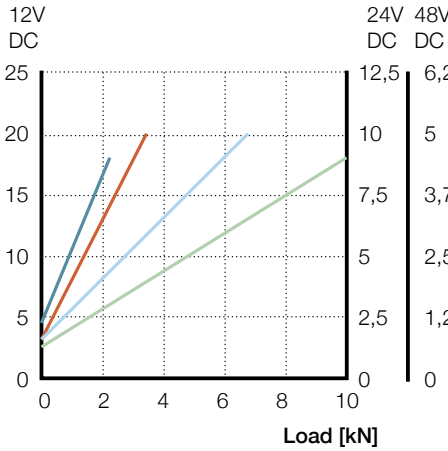

Static load-Stroke length

Load [kN]

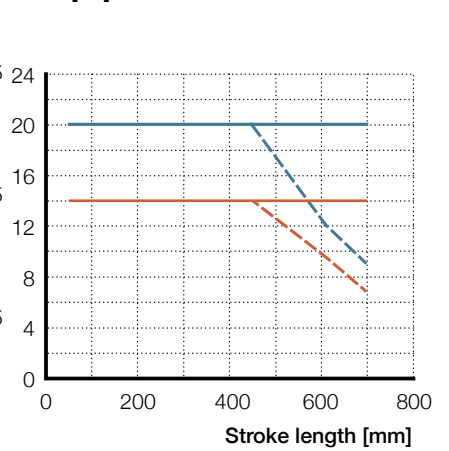

- Ultimate CAHB-22-xxE (pull)
- - Ultimate CAHB-22-xxE (push)
- Recommended CAHB 22-xxE (pull)
- - Recommended CAHB 22-xxE (push)

Speed-Load diagram

Speed [mm/s]

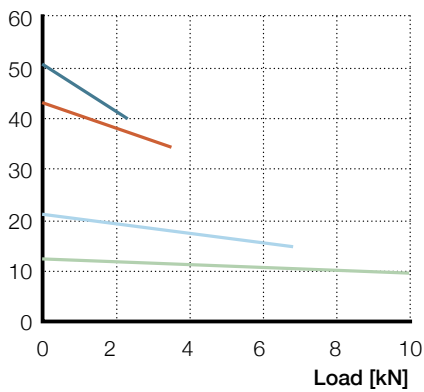

- CAHB-22-x1S
- CAHB-22-x2S
- CAHB-22-x3S
- CAHB-22-x4S

Current-Load diagram

Current consumption [A]

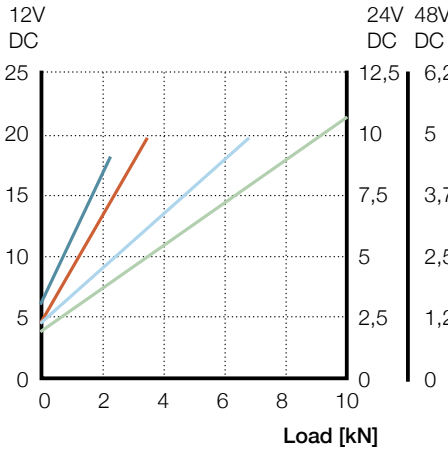

Static load-Stroke length

Load [kN]

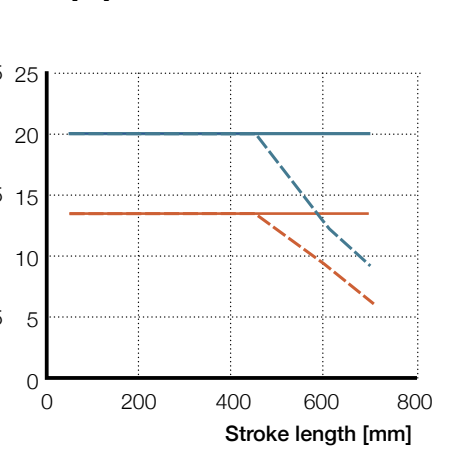

- Ultimate CAHB-22-xxS (pull)
- - Ultimate CAHB-22-xxS (push)
- Recommended CAHB-22-xxS (pull)
- - Recommended CAHB-22-xxS (push)

Dimensional drawing CAHB-22E and -22S

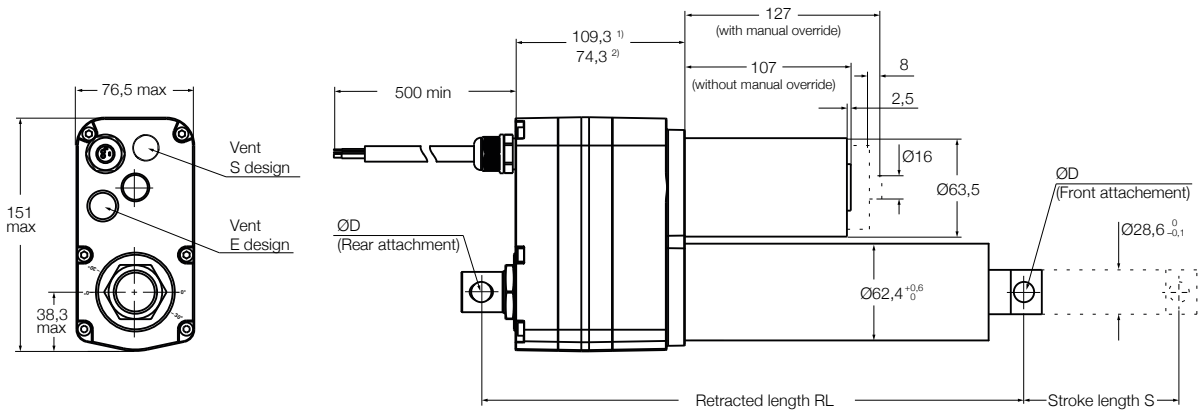

¹⁾ 109,3 for E design with position output

²⁾ 74,3 for E design without position output and S design

	Stroke tolerance	Retracted length tolerance
E design with LS (S<=305)	±2	(0, +4)
E design without LS, 1E/2E (S<=305)	(-3, -1.5)	(0, +4)
E design without LS, 3E/4E (S<=305)	(-2, -0.5)	(0, +4)
E design with LS (S>305)	±3	(0, +4)
E design without LS, 1E/2E (S>305)	(-4, -2)	(0, +4)
E design without LS, 3E/4E (S>305)	(-3, -1)	(0, +4)
S design	±1	±1

Retracted length calculation

Stroke [mm]	Baseline : Rod with hole attachment		Fork head attachment	Anti-rotation tube with free spinning front attachment	Rod end Spherical plain bearing with anti rotation tube	
	50-305	306-700	50-700	50-700	50-305	306-700
CAHB-22E						
Retracted length (RL) no option ¹⁾	194+S	229+S	+12	+7	+49	+37
Retracted length (RL) with LS	200+S	235+S	+12	+7	+49	+37
Retracted length (RL) with position output	229+S	264+S	+12	+7	+49	+37
Retracted length (RL) with LS and position output ²⁾	235+S	270+S	+12	+7	+49	+37
CAHB-22S						
Retracted length (RL)	200+S	235+S	+12	+0	+43	+33

Example for Ordering key, in **red** baseline configuration:

¹⁾ **194 + 50** (stroke) + **12** (Fork head attachment) + **7** (Anti-rotation tube with free spinning front attachment) = **263**

²⁾ **270 + 400** (stroke) + **37** (Rod end Spherical plain bearing with anti rotation tube) = **707**

Electrical specifications (valid for CAHB-20E, -21E, -22E)

Power input voltage tolerance

Power input	Tolerance
12 V DC version	10-16 V DC
24 V DC version	21-26 V DC
48 V DC version	40-55 V DC

Wire connection without position output

Wire no.	AWG	Colour	Application
1	14	Red	Motor power(+) → Extension, (-) → Retraction
2	14	Black	Motor power(-) → Extension, (+) → Retraction

Wire connection with position output

Wire connection with potentiometer			
Wire no.	AWG	Colour	Application
1	22	Green	See picture description
2	22	White	See picture description
3	22	Brown	See picture description
4	14	Red	Motor power(+) → Extension, (-) → Retraction
5	14	Black	Motor power(-) → Extension, (+) → Retraction

Potentiometer

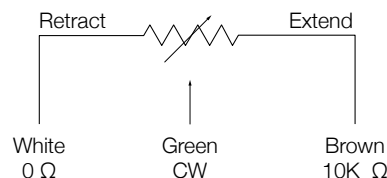

Wire connection with encoder			
Wire no.	AWG	Colour	Application
1	26	Green	Sensor signal 1 Encoder
2	26	Yellow	Sensor signal 2 Encoder
3	26	Black	Sensor power GND Encoder
4	26	Red	Sensor power 5 V Encoder
5	14	Red	Motor power(+) → Extension, (-) → Retraction
6	14	Black	Motor power(-) → Extension, (+) → Retraction

Encoder

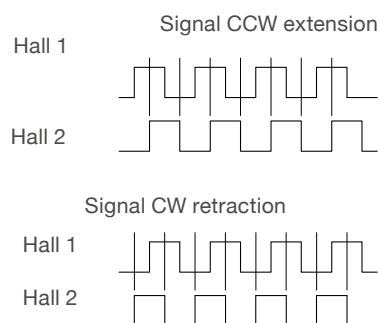

Wire connection with absolute analog output			
Wire no.	AWG	Colour	Application
1	22	Green	Output signal
2	22	White	Sensor power GND
3	22	Brown	Sensor power +10~55 VDC
4	14	Red	Motor power(+) → Extension, (-) → Retraction
5	14	Black	Motor power(-) → Extension, (+) → Retraction

Absolut analog position output

Input voltage: 10~55 V DC
 Current consumption: 15 mA max.
 Output analog signal (voltage): 0~5 V DC
 Max current output: 5 mA
 Absolute analog output set up:
 retracted 0,5±0,15 V
 extended 4,5 V to the maximum

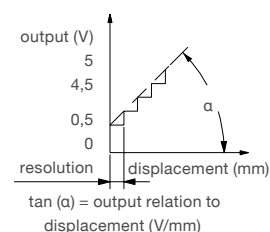

Output relation to displacement and resolution

Actuator type	Hall sensor [pulses/mm]	Potentiometer [Ω /mm]	Absolute analogue position output [V/mm]	Resolution of the absolute analog position output [mm]
CAHB-20...E	2,76	59,06 if S=050-125	0,0295 if S=050-125	0,0413 if S=050-125
		29,53 if S=126-250	0,0148 if S=126-250	0,0827 if S=126-250
		9,84 if S=251-700	0,0049 if S=251-700	0,2480 if S=251-700
CAHB-21...E	1,56	33,33 if S=050-222	0,0167 if S=050-222	0,0732 if S=050-222
		16,67 if S=223-444	0,0083 if S=223-444	0,1465 if S=223-444
		5,56 if S=445-700	0,0028 if S=445-700	0,4395 if S=445-700
CAHB-22...1E	1,4	30 if S=050-254	0,0150 if S=050-254	0,0814 if S=050-254
CAHB-22...2E	1,4	15 if S=255-508	0,0075 if S=255-508	0,1628 if S=255-508
		5 if S=509-700	0,0025 if S=509-700	0,4883 if S=509-700
CAHB-22...3E	2,8	60 if S=050-127	0,030 if S=050-127	0,0407 if S=050-127
CAHB-22...4E	2,8	30 if S=128-254	0,015 if S=128-254	0,0814 if S=128-254
		10 if S=255-700	0,005 if S=255-700	0,2441 if S=255-700

Electrical specifications (valid for CAHB-20S, -21S, -22S)

Analog I/O + CAN bus version (code A and C)

Ordering key pages 37, 39, 41 (Cable and I/O Option 1)

Wire no.	AWG	Colour	Application
1	14	Red	Power (+) VCC Connect to positive 9 to 16 V DC (12 V version) 18 to 55 V DC (24 – 48 V version)
2	14	Black	Power (-) GND Connect to negative
3	26	Red	Extending command 5 to 55 V DC Max. current consumption: 1mA Delay before movement and stop: 50 ms
4	26	Black	Retracting command 5 to 55 V DC Max. current consumption: 1mA Delay before movement and stop: 50 ms
5	26	Yellow	CAN H (CAN bus J1939)
6	26	Blue	CAN L (CAN bus J1939)
7	26	Grey	End stop signal (Digital output, open collector) Normal (L): High-Z Extended (H): Power supply voltage Max. current consumption: 50 mA
8	26	Orange	End stop signal (Digital output, open collector) Normal (L): High-Z Retracted (H): Power supply voltage Max. current consumption: 50 mA
13	26	Green	Analog position signal output Retraction: 0,5±0,02 V Extension: 5 V or 10 V (default) Max. current output: 15 mA Ripple max: 200 mV Transaction delay: 20 ms Linear feedback 0,5% tan(α)=4,5 / stroke (V/mm), code A or 9,5 / stroke (V/mm), code C Resolution: 10 V / 1000 / tan(α)
14	26	White	Analog position sensor power (-) GND Common ground with wire No. 2
15	26	Brown	Analog position sensor power (+) 8 to 27 V DC (0 ~ 5 V output) 13 to 27 V DC (0 ~ 10 V output) Max. current consumption: 15 mA
16	26	Purple	Reserved, not to be connected

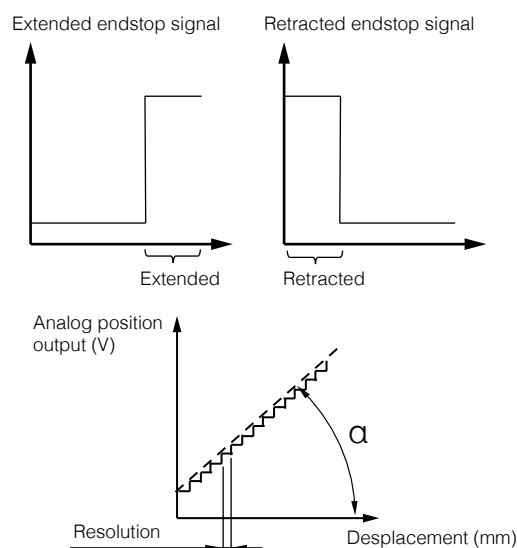
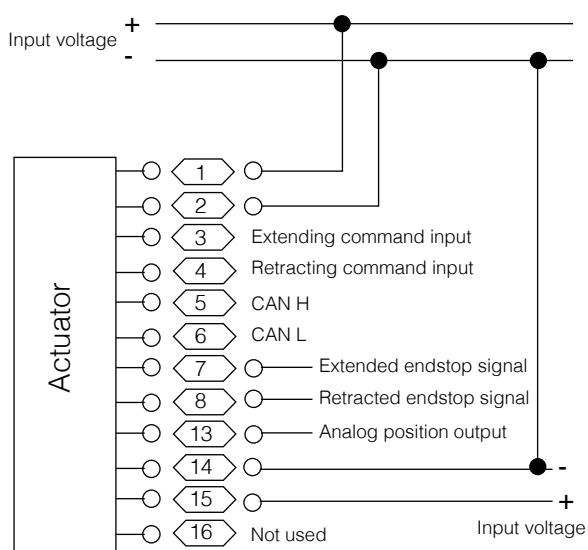

CAN bus + input (Code B)

Ordering key pages 37, 39, 41 (Cable and I/O Option 1)

Wire no.	AWG	Colour	Application
1	14	Red	Power (+) VCC Connect to positive 9 to 16 V DC (12 V version) 18 to 55 V DC (24 – 48 V version)
2	14	Black	Power (-) GND Connect to negative
3	26	Red	Extending command 5 to 55 V DC Max. current consumption: 1mA Delay before movement and stop: 50 ms
4	26	Black	Retracting command 5 to 55 V DC Max. current consumption: 1mA Delay before movement and stop: 50 ms
5	26	Yellow	CAN H (CAN bus J1939)
6	26	Blue	CAN L (CAN bus J1939)

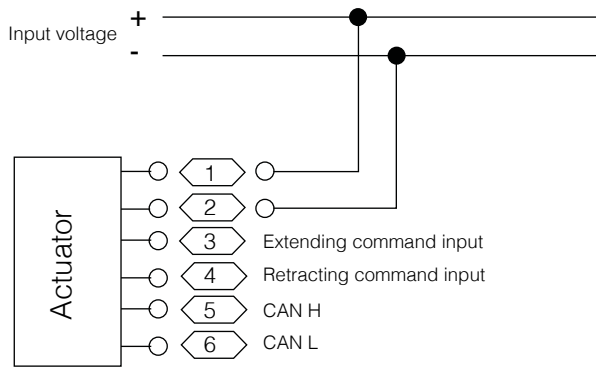

Termination resistance option

Ordering key pages 37, 39, 41 (Bus type Option 2)

Without termination resistor (code C)

With termination resistor (code T)

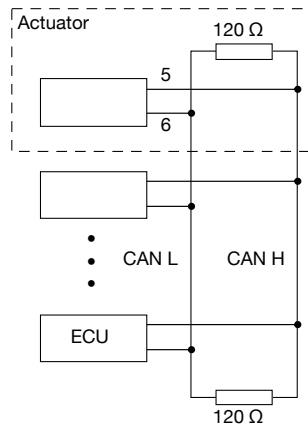
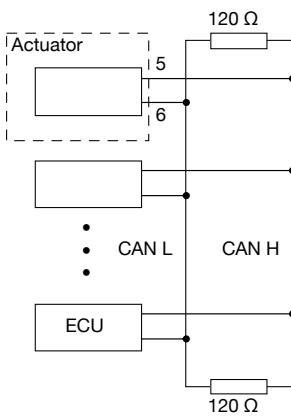

NOTE.

The CAN bus system of the vehicle request termination resistor.

The CAHB 2xS could be equipped one.

Attachment option (valid for CAHB-20, -21, -22 E and S)

Attachment type

Rod end with hole (refer to ordering key Attachment diameter A - E)

Rear attachment

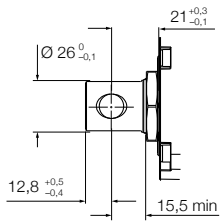

Front attachment without anti rotation tube

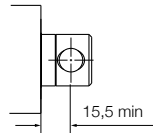

Attachment orientation: "A" to "F"

Front attachment with anti rotation tube

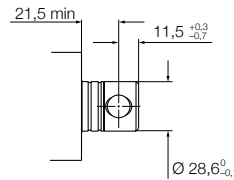

Attachment orientation: "G" to "L"

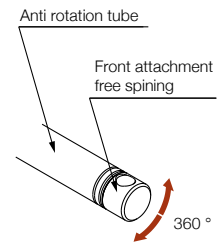

Hole version	A	B	C	D	E
Hole diameter \varnothing [mm]	13,1	12,8	12,5	14	12,2
Tolerance	H11	H11	H11	H11	H11

Fork head with hole (refer to ordering key Attachment diameter F - G)

Rear attachment

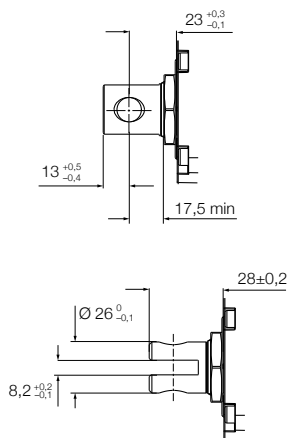

Front attachment without anti rotation tube

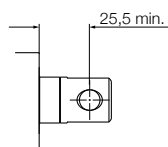

Attachment orientation: "A" to "F"

Front attachment with anti rotation tube

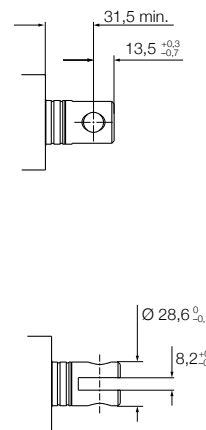

Attachment orientation: "G" to "L"

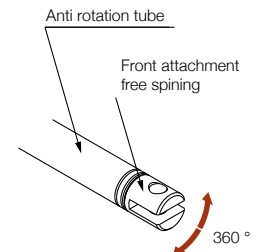

Hole version	F	G
Hole diameter \varnothing [mm]	12,2	12,8
Tolerance	H11	H11

Rod end Spherical plain bearing (refer to ordering key Attachment diameter I)

Rear attachment

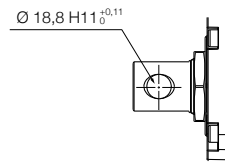

"I" and "B" have the same rear attachment

Front attachment with anti rotation tube

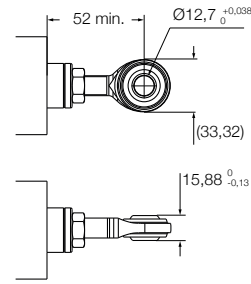

Attachment orientation: "G" to "L"

Hole version	I (Rear Attachment)	I (front Attachment)
Hole diameter \varnothing [mm]	12,8	12,7

Attachment orientation (refer to ordering key Attachment orientation)

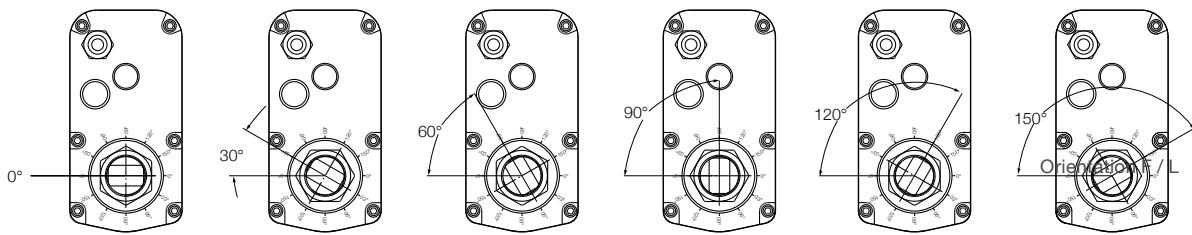

Orientation A / G

Orientation B / H

Orientation C / I

Orientation D / J

Orientation E / K

Attachment orientation	Description
A	0° without anti rotation tube
B	30° without anti rotation tube
C	60° without anti rotation tube
D	90° without anti rotation tube
E	120° without anti rotation tube
F	150° without anti rotation tube
G	0° : with anti rotation tube and free spinning front attachment
H	30° with anti rotation tube and free spinning front attachment
I	60° with anti rotation tube and free spinning front attachment
J	90° with anti rotation tube and free spinning front attachment
K	120° with anti rotation tube and free spinning front attachment
L	150° with anti rotation tube and free spinning front attachment

Manual override

Release the motor cover (1). Use the slot (2) to rotate the motor shaft (3) in the proper direction

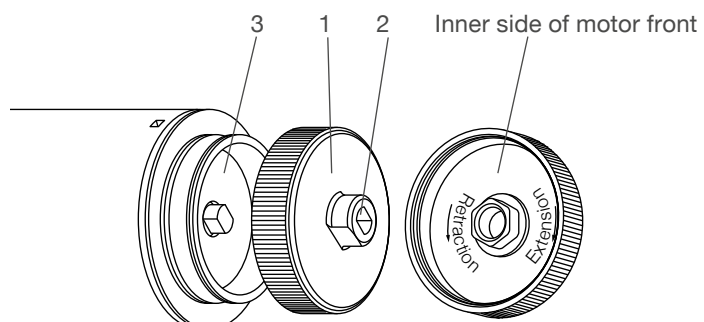

List of function CAHB-20S, -21S, -22S

		CAHB-2xS only	I/O Analog + CAN bus Ordering key Option 1 code A or C	CAN bus + Input Ordering key Option 1 code B	
Interface	Voltage version	12 VDC	●	●	
		24-48 VDC	●	●	
	Cable	Power wires	2	2	
		Low current wires	10	4	
BUS	CAN bus SAE J1939, 250 or 500 kbps	250 kbps or 500 kbps	250 kbps or 500 kbps		
Functions	Motion	soft start / soft stop	●	●	
	E clutch	Force limitation (calibration, temperature compensation)	●	●	
		Adjustable retracted and extended length by I/O and CAN bus	●	●	
	Parallel motion	Drive actuator with the same length , up to	8 pcs	8 pcs	
Parallel motion	Drive actuator with the same length , up to	8 pcs	8 pcs		
Command	Command I/O	Motion Extend / Retract	●	●	
		Motion Extend / Retract	●	●	
	Command CAN bus J1939	Run to an actuator length in 1/10 mm	●	●	
		Speed, command set in %	●	●	
		Set max force in N	●	●	
Real-time feedback	I/O End stop signal	End stop extended	●	–	
		end stop retracted	●	–	
	position feedback by I/O	0-10V or 0-5V absolute analog	●	–	
		CAN bus J1939 feedback	Actuator length in 1/10 mm	●	●
	Force in N		●	●	
	Speed in %		●	●	
	Flag of Endstop retracted		●	●	
	Flag of endstop extended		●	●	
	Flag of run in retraction		●	●	
	Flag of run in extension		●	●	
Diagnostic by CAN bus	Application monitoring		Voltage upper limit reached	●	●
		Temperature upper limit reached	●	●	
		Force upper limit reached	●	●	
		Actuator blocking	●	●	
	Onboard diagnostic / Integrity monitoring	Error code	●	●	
Regulation and test	Compliance	CE marking, Declaration of incorporation for partly completed machine : electricity supply, RoHS, EMC + Reach	●	●	
		Safe Torque Off (STO) SIL 2	Option on request	Option on request	
	Functional Safety	ISO 25119 evaluation	●	●	
		Mechanic	Extended	Extended	
		Climatic	Extended	Extended	
	Environmental test (see pages 50-55)	Electric	Electric	Extended	Extended
			Load Dump protection, chassis connected to negative terminal	●	●
		Load Dump protection, chassis not connected	●	●	
		Reinforced load dump protection ¹⁾ , chassis connected to negative terminal	Option for 12 VDC	Option for 12 VDC	
Reinforced load dump protection ¹⁾ , chassis not connected	Option for 12 VDC	Option for 12 VDC			

● Available

¹⁾ For vehicle without centralized load dump protection



Type

Voltage

- A 12 V DC
- B 24 V DC
- D 48 V DC
- E 12 V DC with manual override
- F 24 V DC with manual override
- H 48 V DC with manual override

Load

- 1 2 300 N
- 2 3 500 N
- 3 6 800 N
- 4 10 000 N

Design

E

Stroke

- 50 50 mm
- 100 100 mm
- 150 150 mm
- 200 200 mm
- 250 250 mm
- 300 300 mm
- 350 350 mm
- 400 400 mm
- 450 450 mm
- 500 500 mm
- 600 600 mm
- 700 700 mm

Retracted length¹⁾

please refer to the table "Retracted length calculation" on **page 27**

Ingress protection

B Standard: IP69K/IP66M

Attachment diameter (Front and rear)

- A Rod end with hole Ø 13,1 mm
- B Rod end with hole Ø 12,8 mm
- C Rod end with hole Ø 12,5 mm
- D Rod end with hole Ø 14 mm
- E Rod end with hole Ø 12,2 mm
- F Fork head with hole Ø 12,2 mm and slot 8,2 mm
- G Fork head with hole Ø 12,8 mm and slot 8,2 mm
- I Rod end Spherical plain bearing Ø 12,7 mm, rear end with hole Ø 12,8 mm (request anti rotation tube option)
- X Customized

Attachment orientation (Front and rear)

- A 0° without anti rotation tube
- B 30° without anti rotation tube
- C 60° without anti rotation tube
- D 90° without anti rotation tube
- E 120° without anti rotation tube
- F 150° without anti rotation tube
- G 0° : with anti rotation tube and free spinning front attachment
- H 30° with anti rotation tube and free spinning front attachment
- I 60° with anti rotation tube and free spinning front attachment
- J 90° with anti rotation tube and free spinning front attachment
- K 120° with anti rotation tube and free spinning front attachment
- L 150° with anti rotation tube and free spinning front attachment
- X Customized

Option 1: Limit switch

- 0 None (mandatory for 1 500 N, 2 500 N version and the 48 VDC version)
- L Limit switch (valid for load version 6 800 N and 10 000 N)

Option 2: Position output

- 0 None
- A Absolute analog output
- P Potentiometer
- E Encoder

Thermal protection

T Standard: Built-in thermal switch

Customization

Stroke length, retracted length, cable, connector, front attachment, rear attachment, color, de-rated load

Standard actuators are IP69K / IP66M and equipped a vent, built-in thermal protection, protection Clutch and EMC filter.

		C	A	H	B	-	2	2	-		S	-																																0	0	0
Type																																														
Voltage																																														
A	12 V DC																																													
B	24 – 48 V DC																																													
E	12 V DC with manual override																																													
F	24 – 48 V DC with manual override																																													
Load																																														
1	2 300 N																																													
2	3 500 N																																													
3	6 800 N																																													
4	10 000 N																																													
Design																																														
S																																														
Stroke																																														
50	50 mm																																													
100	100 mm																																													
150	150 mm																																													
200	200 mm																																													
250	250 mm																																													
300	300 mm																																													
350	350 mm																																													
400	400 mm																																													
450	450 mm																																													
500	500 mm																																													
600	600 mm																																													
700	700 mm																																													
Retracted length																																														
Please refer to the table "Retracted length calculation" on page 27																																														
Parallel operation self-controlled																																														
1	1 actuator run independently																																													
2	2 actuators run simultaneously in parallel mode																																													
3	3 actuators run simultaneously in parallel mode																																													
4	4 actuators run simultaneously in parallel mode																																													
5	5 actuators run simultaneously in parallel mode																																													
6	6 actuators run simultaneously in parallel mode																																													
7	7 actuators run simultaneously in parallel mode																																													
8	8 actuators run simultaneously in parallel mode																																													
Attachment diameter (Front and rear)																																														
A	Rod end with hole Ø 13,1 mm																																													
B	Rod end with hole Ø 12,8 mm																																													
C	Rod end with hole Ø 12,5 mm																																													
D	Rod end with hole Ø 14 mm																																													
E	Rod end with hole Ø 12,2 mm																																													
F	Fork head with hole Ø 12,2 mm and slot 8,2 mm																																													
G	Fork head with hole Ø 12,8 mm and slot 8,2 mm																																													
I	Rod end Spherical plain bearing Ø 12,7 mm, rear end with hole Ø 12,8 mm																																													
X	Customized																																													
Attachment orientation (Front and rear)																																														
G	0° (Standard) with Free spinning																																													
H	30° with Free spinning																																													
I	60° with Free spinning																																													
J	90° with Free spinning																																													
K	120° with Free spinning																																													
L	150° with Free spinning																																													
Option 1: Cabling and I/O variant																																														
A	Analog I/O (Bus, 2 IN, 2 endstop out, Absolute Analog Output 0 – 10 V)																																													
C	Analog I/O (Bus, 2 IN, 2 endstop out, Absolute Analog Output 0 – 5 V)																																													
B	Bus (Bus, 2 IN)																																													
Option 2: BUS Type																																														
C	CAN without termination resistor																																													
T	CAN with termination resistor																																													
Protection																																														
T	Standard : Chassis connected to negative terminal, built-in thermal protection																																													
U	Chassis connected to negative terminal, reinforced load dump protection ¹⁾ , Built-in thermal protection																																													
V	Chassis not connected, Built-in thermal protection																																													
W	Chassis not connected, reinforced load dump protection ¹⁾ , Built-in thermal protection																																													
Customization																																														
Stroke length, retracted length, cable, connector, front attachment, rear attachment, color, de-rated load																																														

¹⁾ For vehicle without centralized load dump protection , option valid only for 12V.